

# Atmos

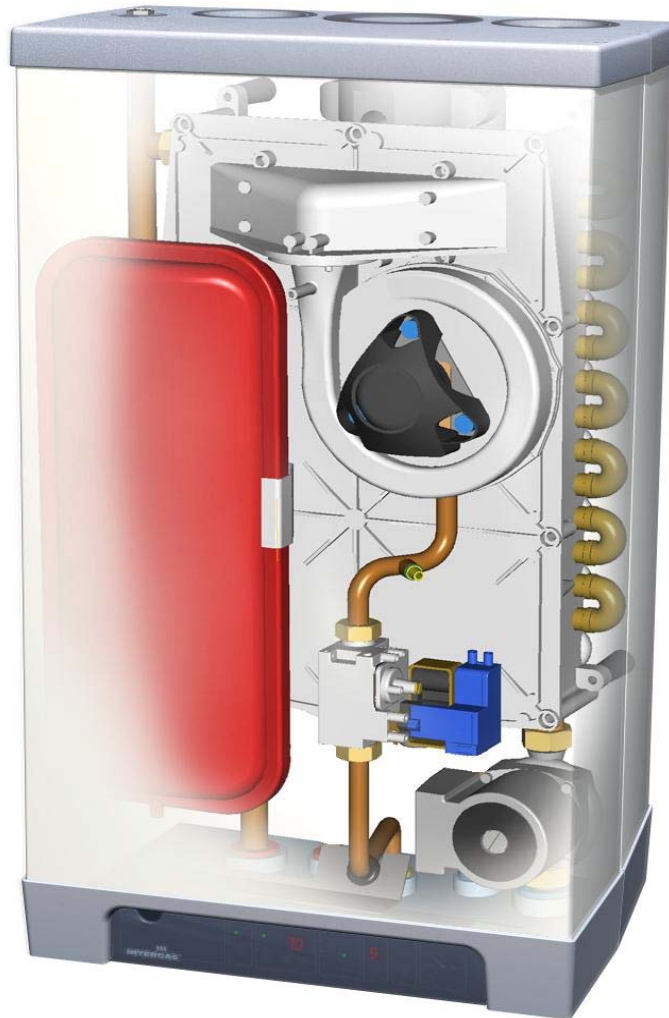

# InterSystem



## **Installation & Servicing Instructions for HE26**

**(GC 41-249-05)**

**Atmos Heating Systems**

**West March**

**Daventry**

**Northants, NN11 4SA**

**Tel: 01327 871990**

**Fax: 01327 871905**

**e-mail: [sales@atmos.uk.com](mailto:sales@atmos.uk.com)**

**internet: [www.atmos.uk.com](http://www.atmos.uk.com)**

Issue 22.01.10 (Main revision)

© 2010 Atmos Heating Systems

The information provided applies to the product in the standard model. Atmos Heating Systems can therefore not be held liable for any damage resulting from the product specifications that deviate from the standard model.

The information provided has been compiled with the utmost care. However, Atmos Heating Systems cannot be held liable for any faults in the information nor for the consequences thereof.

Atmos Heating Systems cannot be held liable for any damage resulting from the activities carried out by third parties.

To be changed without prior notice

## Building Regulations and the Benchmark Checklist

Building Regulations (England & Wales) require notification of the installation of a heating appliance in a dwelling to the relevant Local Authority Building Control Dept. This can be achieved via a Competent Persons Self Certification Scheme as an option to notifying the Local Authority directly. Similar arrangements apply in Scotland and Northern Ireland.

Atmos Heating Systems is a member of the Benchmark Scheme and the Benchmark Checklist is included at the back of these Instructions. The Benchmark Checklist provides a Commissioning Checklist and Service Record to be completed by the Installer/ Service Engineer.

*Benchmark places responsibilities on both manufacturers and installers. The purpose is to ensure that customers are provided with the correct equipment for their needs, that it is installed, commissioned and serviced in accordance with the manufacturer's instructions by competent persons and that it meets the requirements of the appropriate Building Regulations. The Benchmark Checklist can be used to demonstrate compliance with Building Regulations and should be provided to the customer for future reference.*

*Installers are required to carry out installation, commissioning and servicing work in accordance with the Benchmark Code of Practice which is available from the Heating and Hotwater Industry Council who manage and promote the Scheme. Refer to [www.centralheating.co.uk](http://www.centralheating.co.uk) for more information.*



## TABLE OF CONTENTS

<b>1. Safety Regulations</b>	<b>7</b>
1.1 General .....	7
1.2 CH system.....	7
1.3 Gas system .....	7
1.4 Electrical system .....	7
1.5 Domestic water system .....	7
1.6 Flue discharge and air supply .....	7
<b>2. Description of the Appliance</b>	<b>8</b>
2.1 General .....	8
2.2 Operation .....	8
2.3 Operating conditions .....	8
2.4 PC interface .....	10
2.5 Test programmes .....	10
<b>3. Main Components</b>	<b>11</b>
3.1 Accessories.....	12
<b>4. Installation</b>	<b>13</b>
4.1 Overall dimensions.....	13
4.2 Unpacking the appliance.....	14
4.3 Additional dimensions .....	14
4.4 Boiler location.....	15
4.5 Mounting .....	16
4.6 Mount the appliance.....	17
4.7 Fit the pipework cover (optional) .....	17
4.8 Condensate disposal.....	18
<b>5. Connections</b>	<b>19</b>
5.1 Connect the CH system .....	19
5.2 Connecting the gas supply .....	20
5.3 Electrical connection .....	20
5.4 General Flue Requirements .....	23
5.5 Flue discharge and air supply .....	24
5.6 Roof outlet prefabricated chimney.....	30
5.7 Atmos MS System.....	31
5.8 Atmos Communal Flue System (CFS) .....	32
<b>6. Commissioning</b>	<b>33</b>
6.1 Fill and de-aerate the appliance and the system.....	33
6.2 Commissioning of the appliance .....	34
6.3 System Shutdown .....	35
<b>7. Setting and Adjustment</b>	<b>36</b>
7.1 Directly via operating panel.....	36
7.2 Settings through the service code .....	36
7.3 Parameters.....	37
7.4 Setting maximum CH power.....	38
7.5 Setting pump position.....	38
7.6 Weather-dependent control.....	39
7.7 Conversion to other gas type .....	39
7.8 Gas-air control.....	39
7.9 Setting gas-air control .....	40
7.10 Carbon monoxide : carbon dioxide ratio.....	41
<b>8. Faults</b>	<b>42</b>
8.1 Burner does not ignite .....	43
8.2 Burner ignites with much noise .....	43
8.3 Burner resonates.....	44
8.4 No heating (CH) .....	44
8.5 Reduced output.....	45

---

8.6	CH does not reach the correct temperature .....	45
<b>9.</b>	<b>SERVICING THE BOILER AND COMPONENT REPLACEMENT</b>	<b>46</b>
9.1	SERVICING THE BOILER .....	46
9.2	COMPONENT REPLACEMENT .....	48
<b>10.</b>	<b>Technical Specifications</b>	<b>50</b>
10.1	Electrical diagram.....	51
<b>11.</b>	<b>CE Declaration</b>	<b>52</b>

NOTE The Benchmark Checklist & Service Record are included at the back of the Manual.

## This manual

Using this manual you can safely install and maintain this appliance.  
Carefully follow the instructions.

In case of doubt, contact Atmos Heating Systems.

Keep these instructions near the appliance.

## Abbreviations and names used

Description	To be referred to as
High Efficiency	HE
Atmos InterSystem wall-mounted gas heater	Appliance
Appliance with piping for central heating	CH system

## Icons

The following symbols are used in this manual:-



### CAUTION

Procedures that, when not carried out with due care, may result in damage to the product or the environment or in personal injury.

## Service and technical support

For information about specific adjustments, installation, maintenance and repair activities, please contact:

Atmos Heating Systems,  
West March,  
DAVENTRY,  
Northants, NN11 4SA  
Tel: 01327 871990; fax: 01327 871905  
Email: [sales@atmos.uk.com](mailto:sales@atmos.uk.com); internet: [www.atmos.uk.com](http://www.atmos.uk.com)

## Environment



When the appliance needs replacement, your installer may arrange for disposal. Should this not be possible, then make enquiries with your local council about the possibilities for re-use or environmental-friendly processing of the materials used, or contact a scrap dealer about disposal.

Various plastics and metals have been used in producing the appliance. Also, the appliance contains electronic components that are electronic waste.

## Intended use

The appliance as described in this documentation is intended for heating rooms with a central heating system and, if required, heating hot water via an indirect hot water tank. Any other use is outside the scope of intended use for this appliance. Any liability for damage resulting from improper use shall not be accepted.

## Atmos Warranty – Short version

1. Atmos Warranty is against any material, construction or operation faults that are found to be of original manufacturing origin. A full statement of the Atmos Warranty is available ([www.atmos.uk.com](http://www.atmos.uk.com) or 01327 871990).
2. Atmos boiler warranty is, subject to conditions; two years from date of invoice, or 12 months from date of installation; whichever is the later. The warranty shall be 2 years for replacement parts and associated labour, thereafter any warranty period shall cover parts only. The heat exchanger warranty is 10 years in total, including the first two years parts and labour warranty. For purchases before 01/01/08 this extended period was 5 years.
3. We guarantee the free redelivery of parts covered by the warranty. Any alleged faulty part must be returned to Atmos carriage prepaid. Carriage will be credited if the part is found to be manufacturer's fault.
4. Any claim must be accompanied with the serial number of the product.
5. All products must be used in an appropriate application and manner. This includes but is not limited to; correct boiler sizing, system design, system cleansing and use of corrosion inhibitors. Where appropriate and always in areas of "hard water" (in excess of 200 ppm) an approved water conditioner device must be fitted (in accordance with Building Regulations)
6. Completion of the Benchmark Checklist & Service Record is a condition of the boiler warranty (Customer's statutory rights not affected); which must be completed and supplied to Atmos if required. The Warranty card must be completed and the signed Atmos copy received within 8 days of installation. By signing the Warranty card the buyer agrees that the goods have been delivered in a satisfactory condition.

## Exceptions

7. In the event of full payment for a product not being received, Atmos shall be discharged from all further contractual or warranty obligations.
8. Surface and/or transport damage are outside the scope of this warranty.
9. Any warranty provision shall not apply if Atmos determine that the fault is due to improper application, use, neglect, accidental damage or injudicious treatment, non-observance of instructions contained in Atmos Manuals; or due to improper repair, adjustment, installation or maintenance; or due to work carried out by unqualified engineers. The warranty also lapses if the Atmos boiler has not had a yearly service in accordance with instructions.
10. This warranty shall not apply if the fault is caused by scale, failure or abnormality of gas or water supply, or impact of any external influence that adversely affects the normal operation of the product. This shall include but not be restricted to dehydration, abnormal or high voltage, and hard water.
11. Excluded parts: ignition & ionisation probe, glass fuse, and air vent.

## 1. SAFETY REGULATIONS

The appliance must be installed in accordance with the Gas Safety (Installation and Use) Regulations; October 1994. Failure to install appliances correctly could lead to prosecution.

Atmos Heating Systems does not accept any liability for damage or injury caused by not (strictly) observing the current safety regulations and instructions, nor by negligence while installing the Atmos InterSystem wall-mounted gas heater and any accompanying accessories.

The manufacturer's instructions must NOT be taken as overriding statutory requirements.

The regulations are mentioned separately for the different disciplines.

### 1.1 General

The entire system should comply with the valid (safety) regulations, as mentioned in:-

- This installation manual.
- Gas Safety (Installation and Use) Regulations
- The appropriate Building Regulations.
- Health and Safety Document No 635 (Electricity at Work Regulations)
- The Water Fittings Regulations or local Water byelaws.

### 1.2 CH system

The entire system should comply with the valid (safety) regulations, as mentioned in:-

- BS 5449 Central Heating for Domestic Premises.

### 1.3 Gas system

The entire system should comply with the valid (safety) regulations, as mentioned in:-

- BS 6798 Specification for installation of gas fired hot water boilers of rated input not exceeding 60 kW.
- BS 6891 Installation of low pressure gas pipework installations up to 28mm (R1).
- I.S.813 Installation of Gas Appliances (for installations in Ireland).
- British Gas Guidance Notes for the Installation of Domestic Gas Boilers.

### 1.4 Electrical system

The entire system should comply with the valid (safety) regulations, as mentioned in:-

- BS 7671 The IEE Wiring Regulations.

### 1.5 Domestic water system

The entire system should comply with the valid (safety) regulations, as mentioned in:-

- BS 5546 Installation of gas hot water supplies for domestic purposes.

### 1.6 Flue discharge and air supply

The flue discharge and the air supply system should comply with:-

- BS 5440 Flues and Ventilation for gas appliances of rated input not exceeding 60 kW. (Part 1 Flues and Part 2 Ventilation).

## 2. DESCRIPTION OF THE APPLIANCE

### 2.1 General

The Atmos InterSystem wall-mounted gas boiler is designed for delivering heat to the water of a CH system and, if required, heating hot water via an indirect hot water tank.

The air supply and flue discharge can be connected to the appliance by means of two separate pipes or a concentric connection.

The appliance has its own wall mounting strip, but can also be fitted to an optional wall mounting frame that allows top connections. An optional pipe mounting bracket for use with the wall mounting strip is available. These are supplied separately.

The Atmos InterSystem wall-mounted gas boiler has the CE quality mark and the Gas certification labels HE (Sedbuk A), SV, and IP44 Protection class.

The appliance as delivered is suitable for natural gas (G20). A conversion kit for propane (G31) can be supplied upon request.

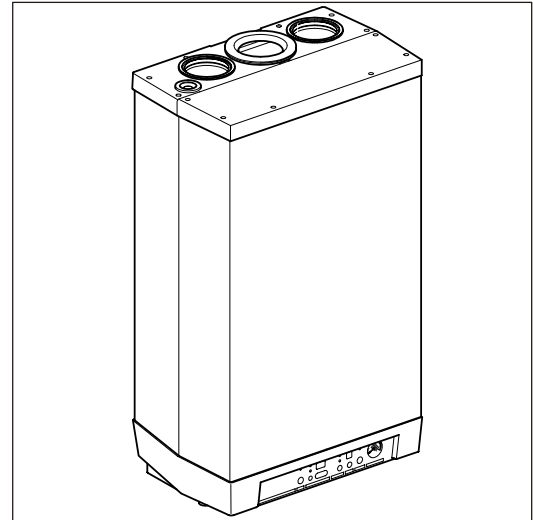

### 2.2 Operation

The Atmos InterSystem wall-mounted gas heater is a modulating high efficiency boiler. This implies that the power is adjusted to the heat demand.

In the aluminium heat exchanger is an integrated copper circuit.

The appliance has been provided with an electronic controller that controls the fan with the heat demand from the heating system or the hot water tank, opens the gas valve and ignites the burner, continuously monitors the flame and controls it dependent on the power required.

### 2.3 Operating conditions

A code indicates the operating condition of the appliance on the service display of the operating panel.

#### Off

The appliance is not operating, but there is electrical power. There is no response to any demand for CH (heating or hot water tank). The frost protection is active though. This means that the pump starts running and the heat exchanger is heated when the temperature of the heat exchanger drops to 5°C.

When the frost protection is activated, code  7 appears (heating of the heat exchanger).

#### Waiting position

The LED of the  on/off button is on. The appliance is ready for responding to the demand for CH (heating or hot water tank).



### **0** Pump overrun

After the operation of the CH, the pump has an overrun. This overrun time is set to the value according to parameter 8 (see § 7.3; factory setting is 1 min). This setting can be changed. Also, the controller will automatically run the pump for 10 seconds, once every 24 hours, to prevent it from getting stuck. This activation of the pump takes place at the time of the last heat demand 24hrs later. In order to change this time, set the room thermostat higher for a while at the desired time.

### **1** Required temperature reached

The controller can temporarily block the heat demand and stop the burner. This blocking takes place because the required temperature has been reached. When the temperature has dropped sufficiently, the blocking is cancelled.

### **2** Self-test

The controller regularly checks the connected sensors. During the check, the controller does not carry out any other tasks.

### **3** Ventilate (Fan)

On starting, the fan is first brought to the starting speed. When the starting speed has been reached, the burner is ignited. Code **3** is also visible after stopping the burner, when post-purge takes place.

### **4** Ignite

When the fan has reached the ignition speed, the burner is ignited by means of electric spark ignition. During ignition the code **4** appears. If the burner is not ignited, another ignition attempt is made after about 5 seconds. If the burner has still not fired after the fourth ignition attempt, the controller indicates a fault. See § 8.1.

### **5** CH operation

An on/off thermostat can be connected to the controller, if necessary in combination with an outside sensor. See the Electrical diagram §10.1. When heat is demanded by a thermostat signal, the fan runs (code **3**) and the burner is ignited (code **4**), followed by the CH operating condition (code **5**).

During CH operation, the fan speed and hence the power of the appliance is adjusted. This is done in such a way, that the temperature of the CH water is controlled towards the set CH supply temperature. In the case of an on/off thermostat, the CH supply temperature is set at the operating panel. In the case of an outside sensor, the CH supply temperature is determined by the weather dependent control programmed in the controller.

During CH operation, the demanded CH supply temperature is displayed on the operating panel.

During CH operation, the actual CH supply temperature can be read by pressing the service button.

**Note:** Instead of an on/off thermostat, an OpenTherm thermostat can be connected to the controller as described in §5.3.1. In this case, the desired CH temperature is set by the thermostat. The minimum

temperature and the operation mode can be set with parameters [E] and [E.] (refer to §7.3).

## 2.4 PC interface

The controller has an interface for a PC. With a special cable and accompanying software, a PC can be connected. This provision makes it possible to follow the behaviour of the controller, the appliance and the heating system during a long period.

## 2.5 Test programmes

In the controller, there is provision for putting the appliance into a test status.

By activating a test programme, the appliance will become active with a fixed fan speed without intervention of the control functions. The safety functions remain active though.

Simultaneously press + and – to switch off the test programme.

### Test programmes

Description of programme	Button combinations	Display reading
Burner on with minimum CH power	"service" and "-"	"L"
Burner on with maximum CH power	"service" and "+" (1x)	"h"
Burner on with maximum power (set by parameter 4)	"service" and "+" (2x)	"H"
Switch off test programme	"+" and "-"	Current operating condition

### 2.5.1 Frost protection

The boiler has provision for protecting its heat exchanger as described below.

**NOTE!** However to avoid the condensate freezing, the boiler must be installed in a FROST-FREE room.



- In order to avoid freezing of the appliance (heat exchanger), it has an appliance frost protection. When the temperature of the heat exchanger drops to 5°C, the burner will be activated and the pump will start running until the temperature of the heat exchanger reaches 10°C. Code 7 is given when the appliance frost protection intervenes (heating heat exchanger).
- When the system (or a part thereof) can freeze, a frost thermostat should be installed in the area to be protected. Connect this according to the wiring diagram. See § 10.1.

#### Remark

When the appliance is out of action ( - on the service display), the appliance frost protection is still active. However, there will be no response to heat demand from an (external) frost thermostat.

### 3. MAIN COMPONENTS

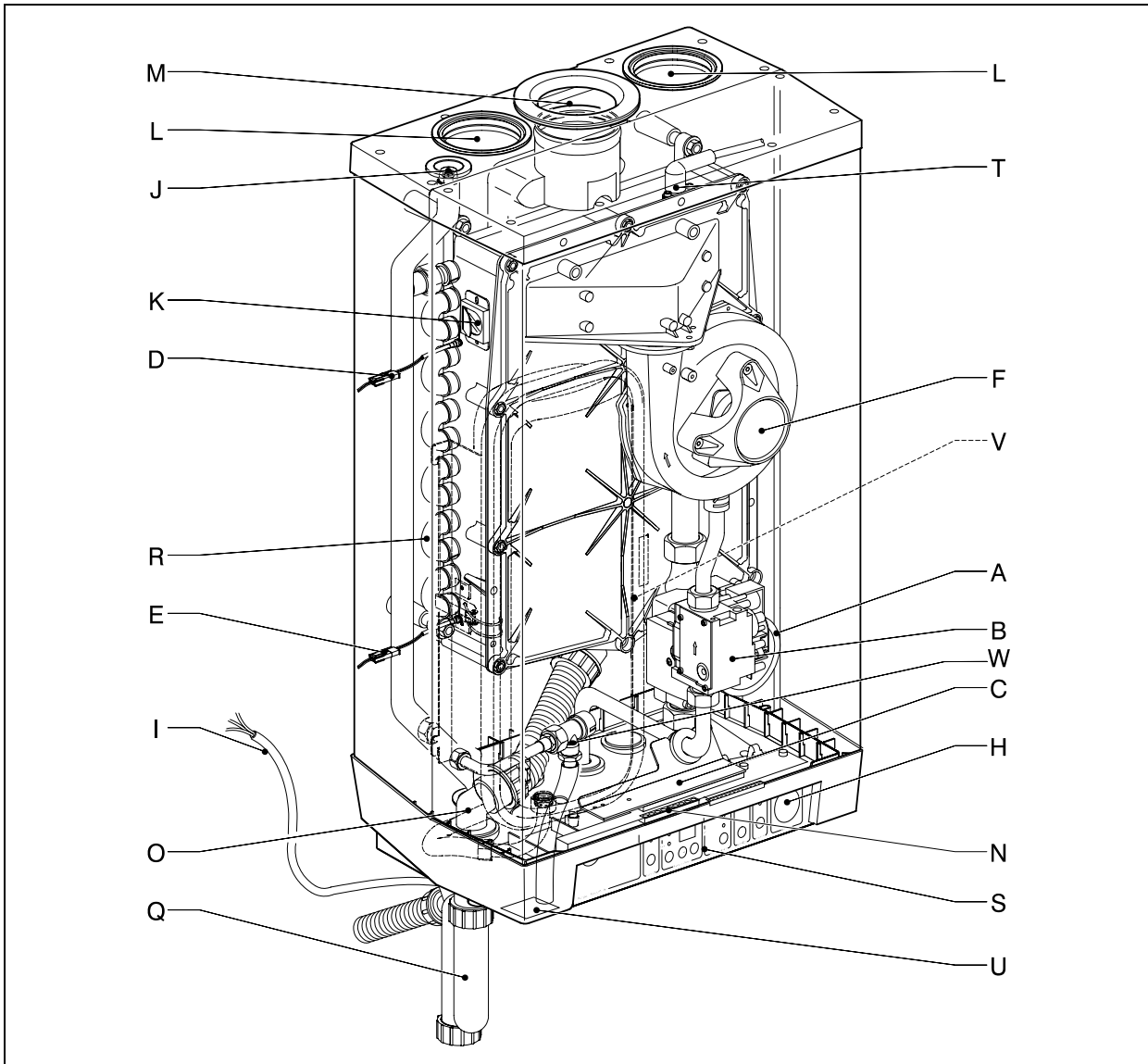

A	CH pump	M	Flue discharge (or concentric connection)
B	Gas valve	N	Connecting block / terminal list X
C	Clamping plate	O	Condensate discharge
D	Supply sensor S1	Q	Codensate trap
E	Return sensor S2	R	Heat exchanger
F	Fan	S	Controller operating panel and display
H	Pressure gauge	T	Ionisation/ignition probe
I	1m connecting cable 230 V ~	U	Position type plate
J	Manual air vent	V	Expansion vessel (shown in broken lines)
K	Sight glass and mirror	W	Pressure relief safety valve, 3 bar
L	Air supply (left or right)		

Additional Components supplied :-

Valve set (supplied separately with boiler)

### 3.1 Accessories

Description	Part Ref
<b>Pipe mounting bracket</b> <ul style="list-style-type: none"> <li>• Connection supply and return 22 mm diameter</li> <li>• Connection gas ½" female thread</li> <li>• Mounting strip boiler</li> <li>• Bag with fixings</li> </ul>	092.537
<b>Rear mounting frame for top pipe connection</b>	092507
<b>Bottom Pipework cover</b>	092527
<b>Outside sensor for weather compensation</b>	203.207
<b>Conversion set to Propane (LPG or G31)</b>	075537
<b>Interface cable (for Installers)</b>	230677

## 4. INSTALLATION

### 4.1 Overall dimensions

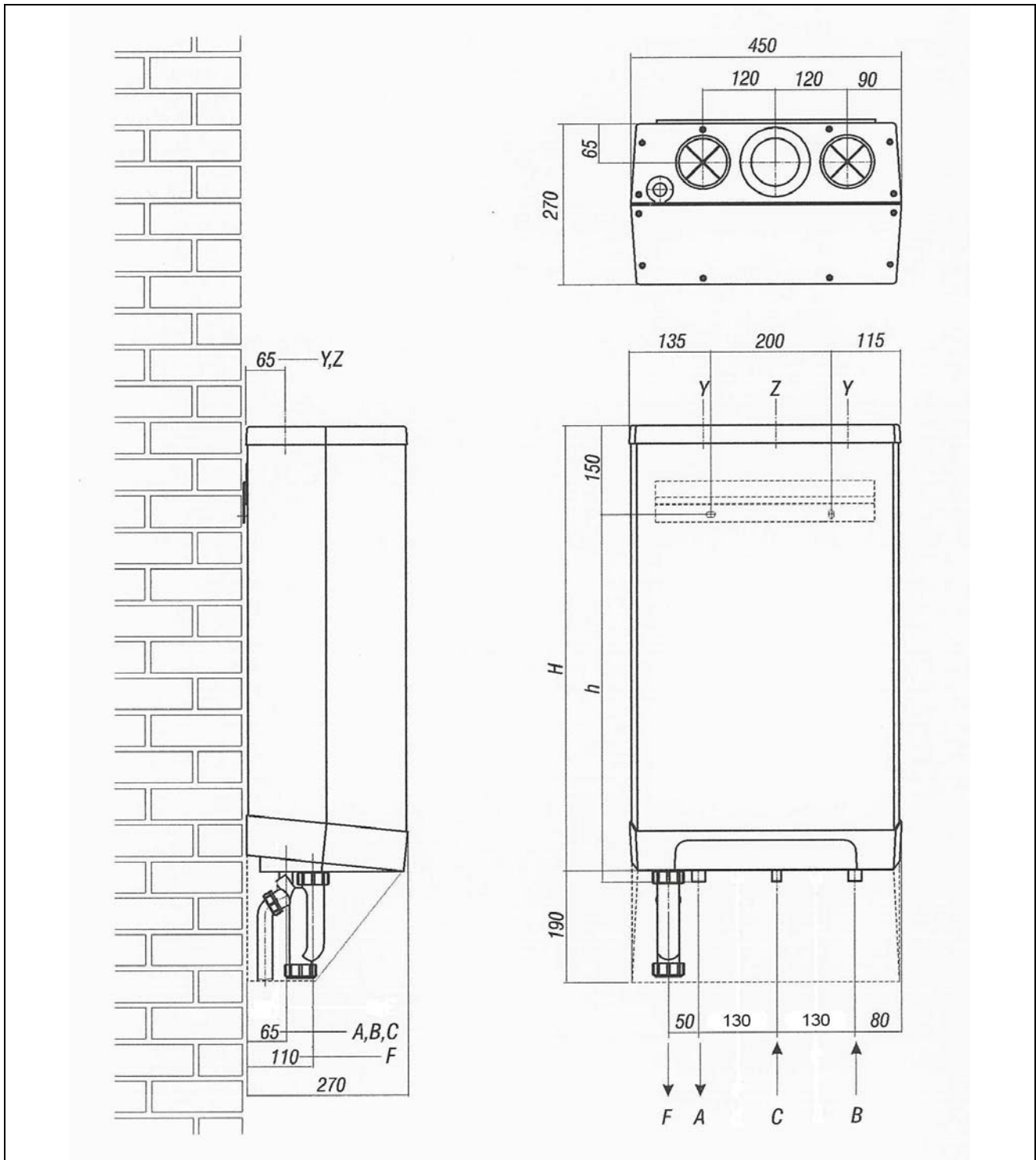

A=	CH flow	22 mm diameter	h=	670mm	InterSystem HE 26
B=	CH return	22 mm diameter			
C=	Gas	15 mm diameter	H=	810mm	InterSystem HE 26
			Z=	Flue gas outlet	80 mm diameter
F=	Condensate	32 mm dia (after trap 25 mm dia flexible)	Y=	Air supply inlet	80 mm diameter

## 4.2 Unpacking the appliance

1. Unpack the appliance.
2. Check the content of the packaging. This consists of:-
  - Appliance (A)
  - Mounting strip (B)
  - Condensate trap (C)
  - Installation Instructions
  - User Operating Instructions
  - Warranty card
3. Valve set (supplied separately with boiler) comprising 2 x 22mm isolation valves, 1 x gas valve.
4. Check the appliance for any damage: report damage to the Supplier immediately.

**CAUTION:** This appliance should be lifted and handled by 2 people.  
(Weight: 39 kg)

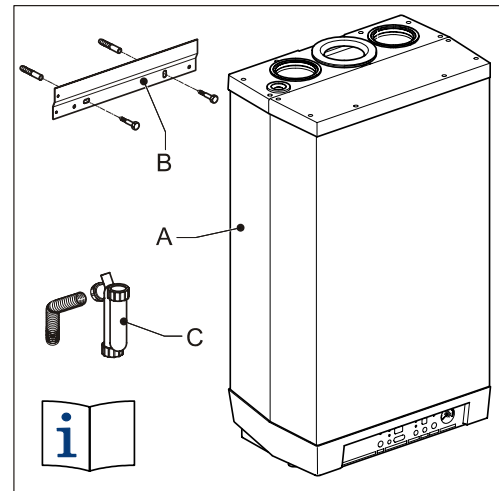

## 4.3 Additional dimensions

The diagram shown below gives additional dimensions primarily for the mounting arrangement using the **OPTIONAL** mounting bracket.

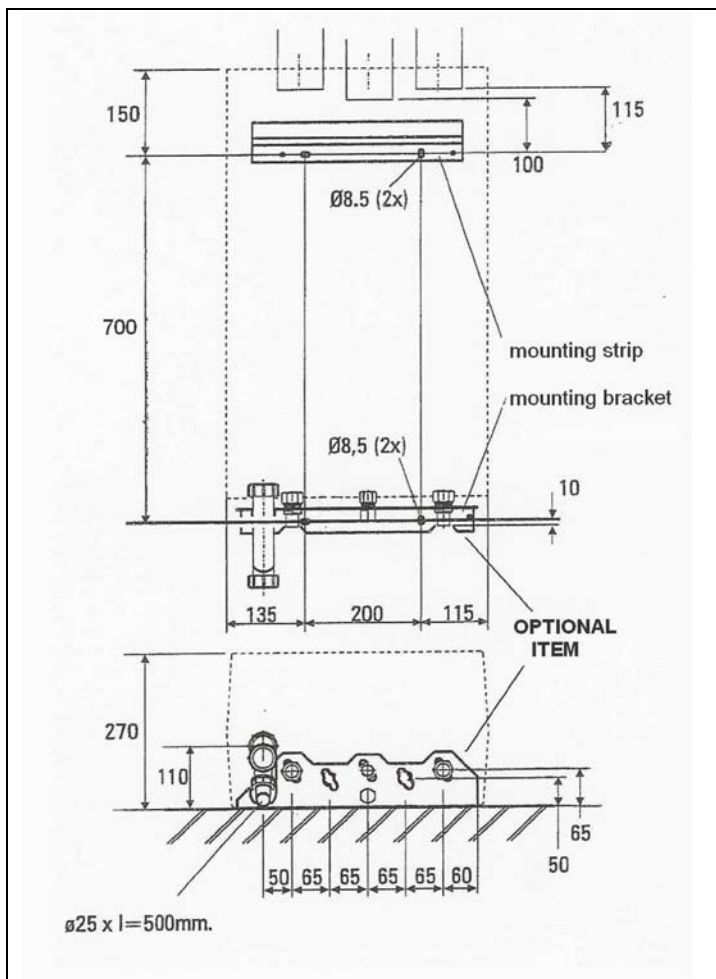

**Note:** The centre line of the hexagonal notch in the mounting bracket is also the centre line of the flue hole.

## 4.4 Boiler location

### Clearances

Above casing	200mm min
Below casing	230mm min
RH	30mm min
LH	30mm min (in operation)
LH	140mm min (servicing)
Front	30mm min (in operation)
Front	450mm min (servicing)

Keep 50 mm free space above the front panel in order to be able to remove the front panel from the casing. Allow 140 mm on the left side for swinging out the expansion vessel during commissioning/service.

The appliance can be fitted to a mounting frame. The assembly or just the appliance should be mounted to a wall with sufficient bearing strength. In case of light wall constructions, resonance sounds may occur.

The appliance is suitable for mounting on a combustible wall (eg stud wall).

There must be an earthed electrical supply within a distance of 1 m from the appliance.

In order to avoid freezing of the condensate discharge, the appliance should be installed in a frost-free room.

### 4.4.1 Installation in a kitchen cupboard

Make sure there is sufficient ventilation above and below the appliance. When the appliance is placed in a small cupboard, ventilation openings of at least 50 cm<sup>2</sup> must be made.

### 4.4.2 Installation in an airing cupboard

Compartment ventilation is not required for a standard airing cupboard (eg 0.6 x 0.6 x 2.3m high).

### 4.4.3 Remove front panel

Remove the optional pipework cover and the front panel for carrying out work on the appliance as follows:-

1. Remove the pipework cover (A), if used, forwards.
2. Unscrew both recessed crosshead screws (B) at the bottom of the appliance.
3. Lift the front panel (C) vertically upwards and remove it forwards.

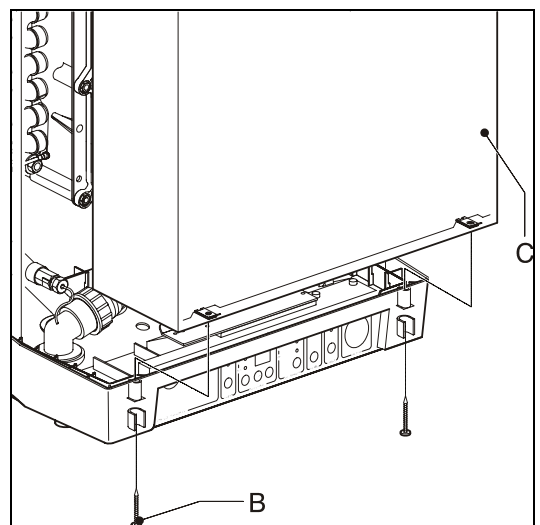
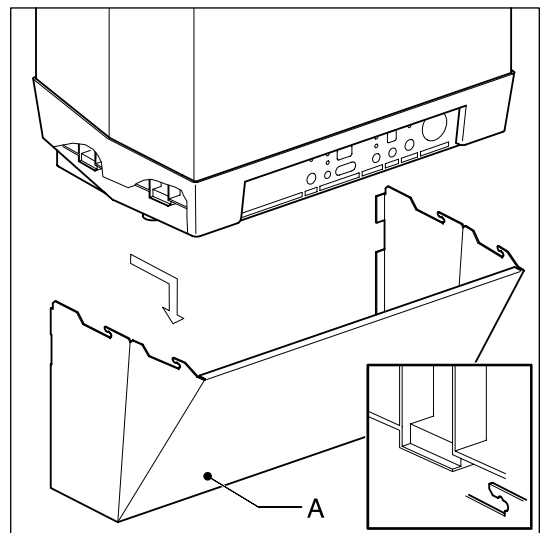
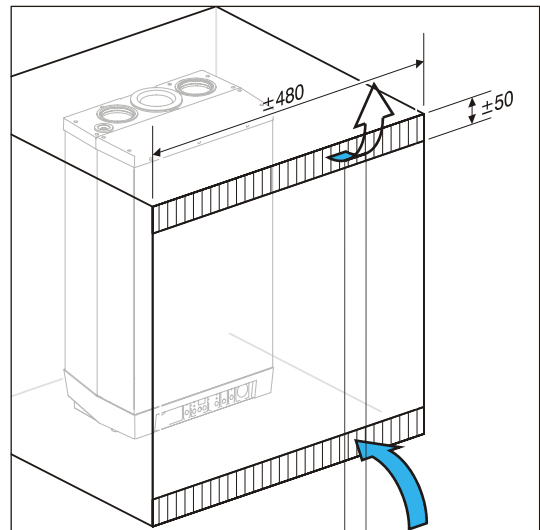
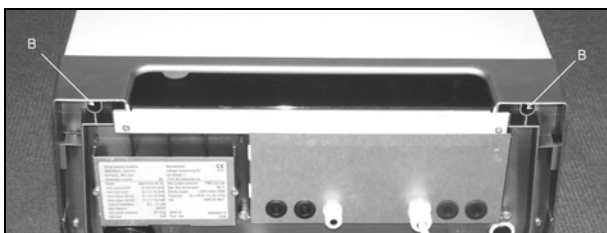

## 4.5 Mounting

Depending on the mounting option ordered, the following mounting methods are available:-

Mounting strip (A) alone,

OR mounting strip (A) and *optional* pipe mounting bracket (B),

OR rear mounting frame (C) and pipe mounting bracket (B), which are both *optional* items. This arrangement allows for vertical pipework behind the boiler.

**Note that when the pipe mounting bracket is used, the pipes can be connected before installing the appliance.**

### 4.5.1 Fitting the mounting strip

1. Fasten the mounting strip horizontally to the wall, using the screws and plugs supplied.
2. Mount the appliance.

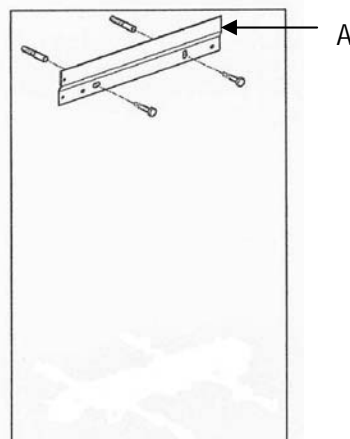

### 4.5.2 Fitting the mounting strip and the mounting bracket

1. Fasten the mounting strip and the pipe mounting bracket horizontally to the wall according to the drilling pattern, using the screws and plugs supplied.

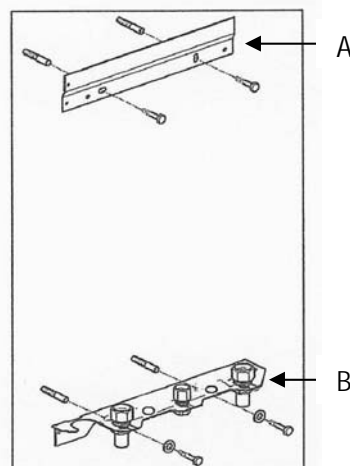

### 4.5.3 Fitting the rear mounting frame

1. Fasten the frame vertically to the wall, using screws and plugs.
2. Fasten the optional pipe mounting bracket to the frame using the fixings supplied.

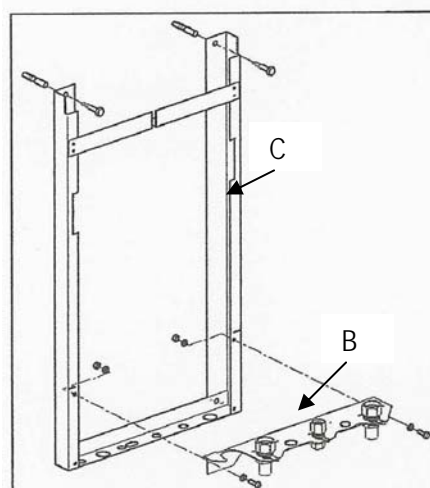

### Caution

*The appliance is wider than the frame by 20mm.*



#### 4.5.4 Installation connections

1. Make the various connections to the valves (see diagram).
2. Install a filling loop (not supplied) between the cold water inlet pipe and the CH return connection.
3. For most installations, the flexible tube for the safety discharge will be long enough to fit into the condensate discharge waste pipe (see below). In cases where this does not apply, install a 15 mm copper safety discharge pipe to fit into the waste pipe (as shown in the diagram, §5.1) or run separately to a safe discharge position on the outside wall of the building.

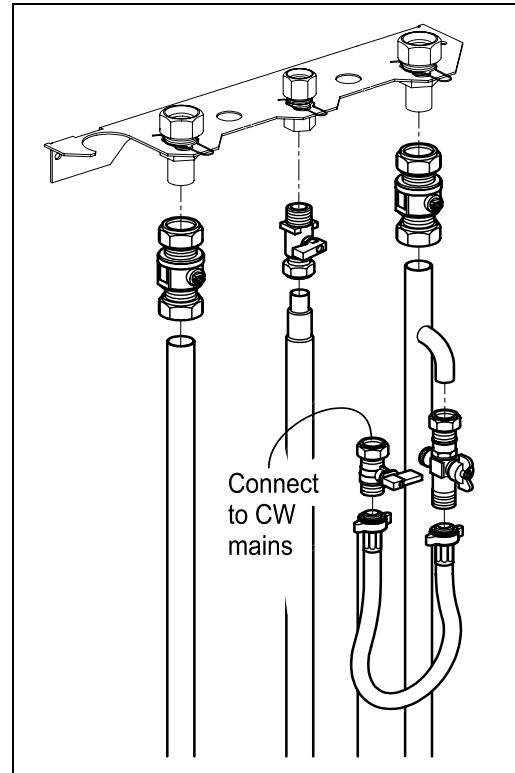

#### 4.6 Mount the appliance

1. Check whether the compression rings of the optional mounting bracket are straight in the connectors.
2. Place the appliance: slide it top-down over the mounting strip. Make sure that the pipes simultaneously slide into the compression fittings of the optional mounting bracket.
3. The flexible tube from the condensate trap should be inserted into an open waste pipe of not less than 32 mm diameter. If connected to a soil pipe or waste system, the waste pipe must include a trap (similar to arrangement for washing machine). For more information on condensate disposal, please refer to §4.8.
4. The flexible tube from the pressure relief safety valve should be inserted into the waste pipe, or pushed over the 15 mm copper discharge pipe if provided.
5. Tighten the compression fittings to the optional mounting bracket.
6. Mount the air supply and the flue discharge.
7. Close the air supply opening that is not used with the plug supplied.

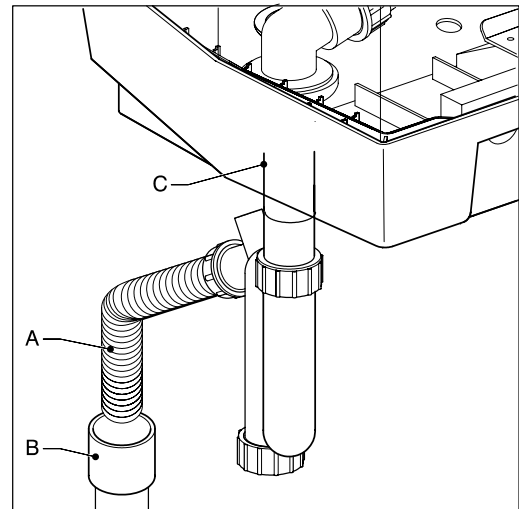

#### 4.7 Fit the pipework cover (optional)

1. Insert the four hooks of the pipework cover in the slots of the appliance.
2. Slide the cover backwards, sliding the hooks into the slots and locking the cover.

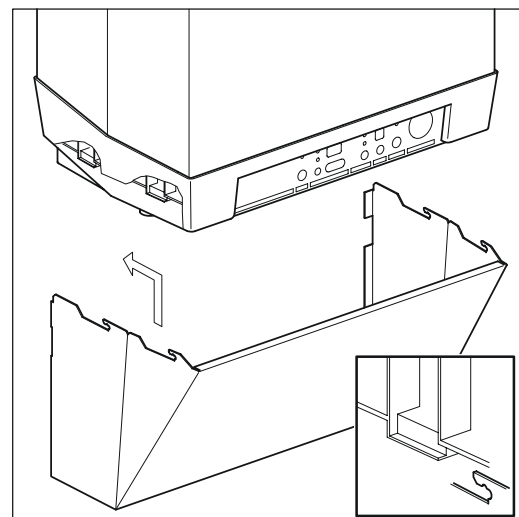

## 4.8 Condensate disposal

The appliance is provided with a 25 mm flexible pipe from its condensate trap. As given in §4.6, this should be inserted into an open waste pipe of not less than 32 mm diameter, together with the safety discharge pipe. The condensate is slightly acidic (pH between 3 and 6) and should be disposed of in the following ways, using suitable plastic waste pipe (Note: copper or steel must not be used):-

- internal stack pipe (see diagram)
- waste pipe (see diagrams)
- external drain or gulley
- purpose made soakaway

The pipework must incorporate a minimum fall of 2.5 degrees (or 44mm/metre) towards its point of termination. The condensate pipework external to the property, or in an unheated part (eg a garage), must be suitably insulated to protect against freezing, and the length of the external pipe restricted to a maximum of 3 metre.

If an external drain or gulley is used, then the open end of the pipe should be terminated below the grid level, but above the water level.

If a proprietary soakaway is used, install at least 1 metre away from the external wall and clear of foundations and services. The soakaway is buried in the ground and surrounded by limestone chippings to neutralise the condensate.

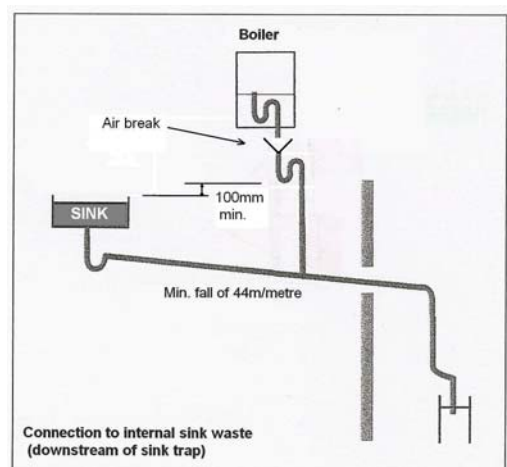
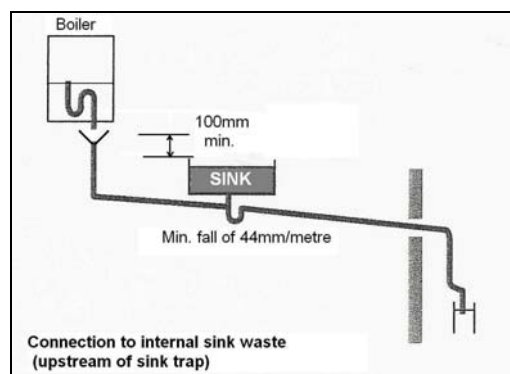
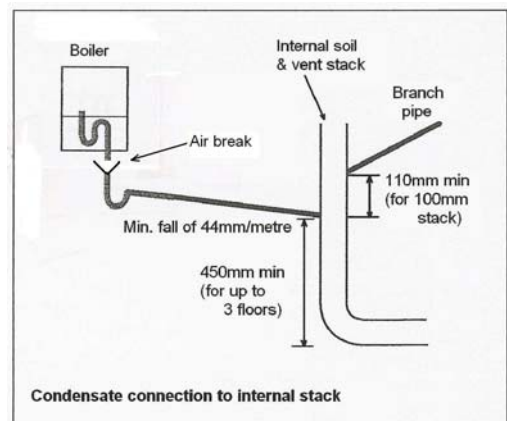

## 5. CONNECTIONS

### 5.1 Connect the CH system

1. Flush the CH system thoroughly.
2. Connect the flow and return pipes to the mounting bracket.  
All pipes must be mounted tension-free in order to avoid ticking of the pipes.  
Existing connections must not be twisted in order to avoid leaks at the connections with the external pipes.

The CH system should be provided with:-

- A filling loop in the return pipe directly below the appliance.
- A drain tap at the lowest point of the system.
- An additional expansion tank if required (see 5.1.1).

#### 5.1.1 Expansion vessel

The appliance is fitted with a 6 litre expansion vessel which is adequate for a system with a water volume not exceeding 100 litres, typically 8 radiators. For larger volume systems, an additional expansion vessel must be fitted. Atmos can supply 12 litre or 18 litre Robokit.

#### 5.1.2 Thermostatic radiator valves

Building regulations require a room thermostat to be fitted on all installations. Do not fit a thermostatic valve on the radiators in the room where the thermostat is situated, otherwise the controls will not function correctly.

#### 5.1.3 System bypass

A by-pass is not required for safe operation of the boiler. For heating systems where there are thermostatic valves on all radiators, or where there are other system flow restrictions such as zone valves, a by-pass should be fitted to reduce system noise and to protect the pump. The by-pass should comprise a proprietary by-pass valve with adjustable flow regulation, not a fixed setting valve. Atmos can supply this valve.

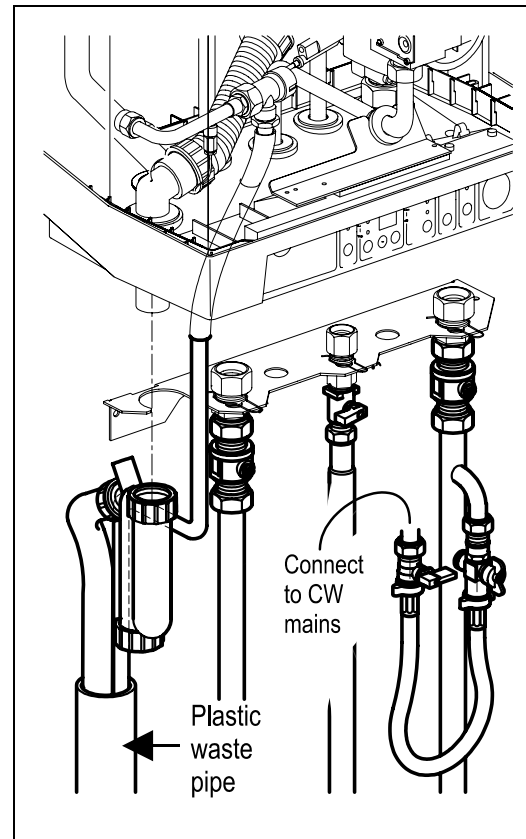

#### Note

The flexible tube from the pressure relief safety valve can be inserted directly into the waste pipe if suitably located. The flexible tube must be installed so that there are no sharp bends that kink the pipe and cause a restriction in the flow.

## 5.2 Connecting the gas supply

1. Connect the appliance gas valve to the gas pipe.
2. Check the boiler's data plate to ensure that the appliance has been set for the correct gas supply. The boiler is supplied for Natural Gas (G20). A propane (G31) gas conversion set is available and an appropriate sticker is included (see §7.7).
3. The meter governor should deliver a dynamic pressure of 20mbar for natural gas or 37mbar for propane.
4. To prevent the ingress of foreign matter and possible damage to the gas-regulating block, the gas supply pipe must be checked for contaminants prior to connection to the boiler. Install a gas filter if necessary.
5. On final connection of the gas supply to the boiler, the complete gas installation, including the meter, must be tested for gas tightness and purged as described in BS6891.

## 5.3 Electrical connection



### CAUTION

The appliance requires a 230 V ac 50 Hz mains supply, and must be earthed and connected via a double pole isolating switch fitted with a 3 amp fuse. The switch must be readily accessible, within 1m of the appliance, and provide complete electrical isolation for the boiler and control system.

The appliance is supplied factory wired complete with 1 m of mains cable. All electrical connections to the mains supply must be made in full accordance with the current I.E.E. regulations (BS 7671).

Isolate the supply by opening the double pole switch when carrying out maintenance activities.

6. Remove the optional pipework cover forwards.
7. Unscrew the screws (A) in order to gain access to the space of the controller (B).
8. The cover plate (& display) hinges open downwards. This gives access to the controller and electrical connections.
9. Consult § 5.3 and § 10.1 for making connections.
10. After having made the required connections, connect the appliance to a switched supply, as given above.

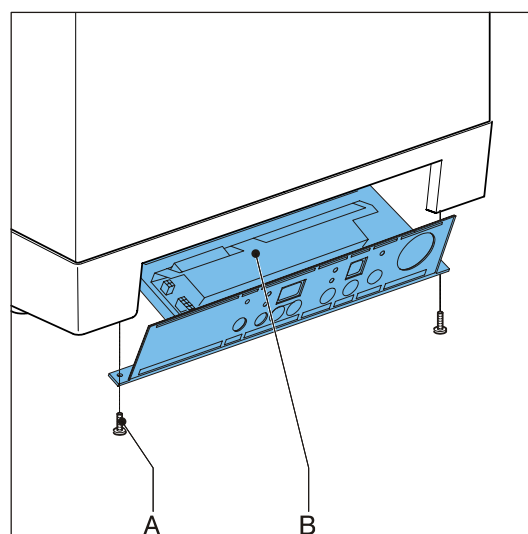

## Controller Label and Associated Terminals

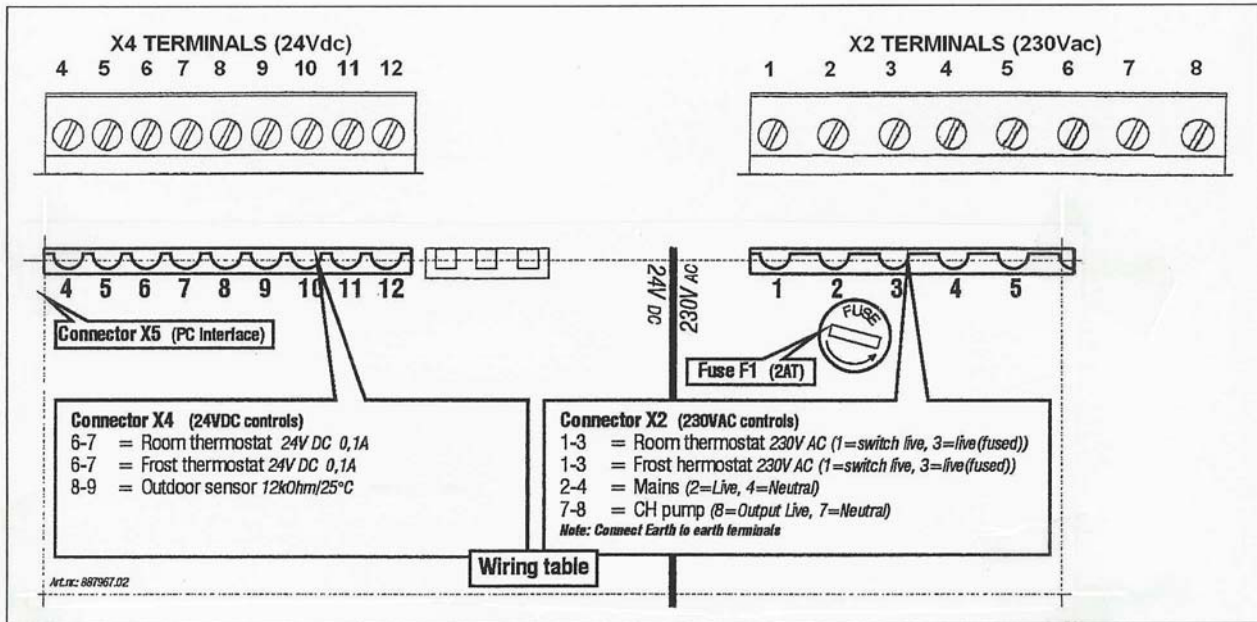

Note: Terminals X4/11 & 12 are available for OpenTherm modulating stat.

### 5.3.1 24V dc Electrical connections

#### 24V dc Terminals X4

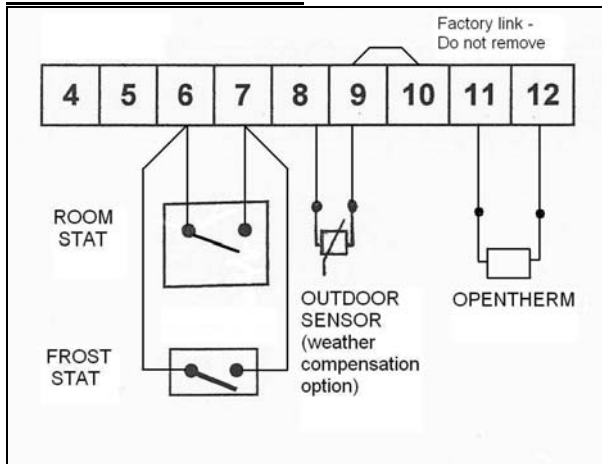

Description	Connector X4	Remarks
Room stat	6 - 7	6= +24Vdc
Outside temp sensor	8 - 9	
OpenTherm modulating stat	11 - 12	6 - 7 not used
Frost stat	6 - 7	Parallel through room stat
Power 24Vdc (3VA)	6= +24Vdc, 9= .	

#### Notes

- Under no circumstances must any electrical power be input to the room thermostat terminals. It is a volt-free switch.
- Care must also be taken to avoid induced voltages caused by the running of the thermostat cables along side mains voltage cables.

### 5.3.2 Volt free Room thermostat on/off

- Connect the room thermostat. See § 5.3.1.
- The terminal block for the connection for a volt free room thermostat, or time clock, is X4 on the control panel. The terminals are wired to the input circuit of the control unit, which has its own 24V dc 'wetting voltage'.
- If using a room thermostat with heat accelerator, this must be set at 0.1A.
- The maximum permissible resistance of the room thermostat circuit and cable is 15 Ohms.
- Where a 'wireless' room thermostat is employed, consult the manufacturer's instructions for installation.

### 5.3.3 Outside temperature sensor (Weather compensation option)

The appliance has a connection for an outside temperature sensor. The outside temperature sensor can be applied in combination with an on/off room thermostat or time clock. If not using either of these, a wire link must be made across X4/6 & 7 (or X2/1 & 3) to give continuous operation.

Preferably, the outside sensor should be mounted on a North facing wall. It should not be located where it might be affected by (the warmth of) sun light, chimneys, air vents or an open window.

To avoid problems with moisture, the sensor should be placed with the cable outlet downwards and the cable looped so that the lowest part of the cable is lower than the hole in the wall. Run the cable back to the appliance, ensuring that holes in walls are sealed, and pass through a suitable cable gland in the bottom of the appliance.

Connect the outside temperature sensor cable to the controller as shown in § 5.3.1.

See Weather-dependent control § 7.6 for the setting of the CH temperature line.

#### WARNING!

When the boiler is also used to heat a hot water storage tank it is necessary to run the outside temperature sensor cable via a relay. This relay needs to be wired so that the outside sensor electrical circuit is opened whenever there is a call for heat for hot water.

### 5.3.4 OpenTherm modulating thermostat

The appliance is suitable for connecting an OpenTherm modulating thermostat as shown in § 5.3.1.

The most important function of the modulating thermostat is calculating the supply temperature at a required room temperature in order to make optimum use of the modulating function. With every heat demand, the appliance display shows the required supply temperature.

The manual supplied with the OpenTherm thermostat should be consulted for more information.

**NOTE!** When connecting an OpenTherm modulating thermostat to a boiler that is also used to heat a hot water storage tank, please contact Atmos for wiring instructions.

### 5.3.5 230Vac Electrical connections

#### 230Vac Terminals X2

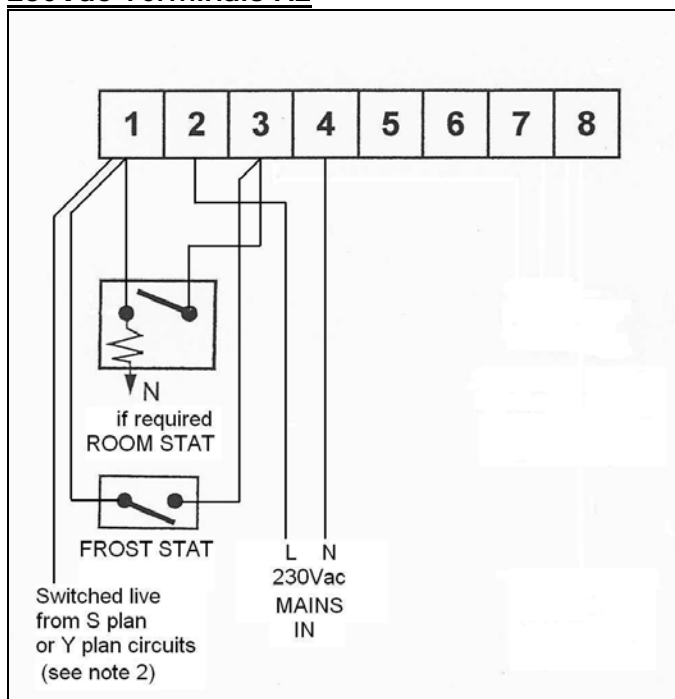

Description	Connector X2	Remarks
Mains In	L= 2, N= 4	Earth: see §10.1
Room stat	1= switch live, 3= live (fused)	
Frost stat	1 - 3	Parallel through room stat

#### Notes

1. The 230Vac stat circuits are alternative to the 24Vdc circuits. If the stat has a neutral connection for heat accelerator, then connect it for more efficient operation.
2. The switched live can also be used for S plan or Y plan circuits (note that the 230Vac live to the Wiring Centre must come from the same fused spur as the 230Vac supply to the boiler).



## 5.4 General Flue Requirements

### 5.4.1 Flue terminal clearances

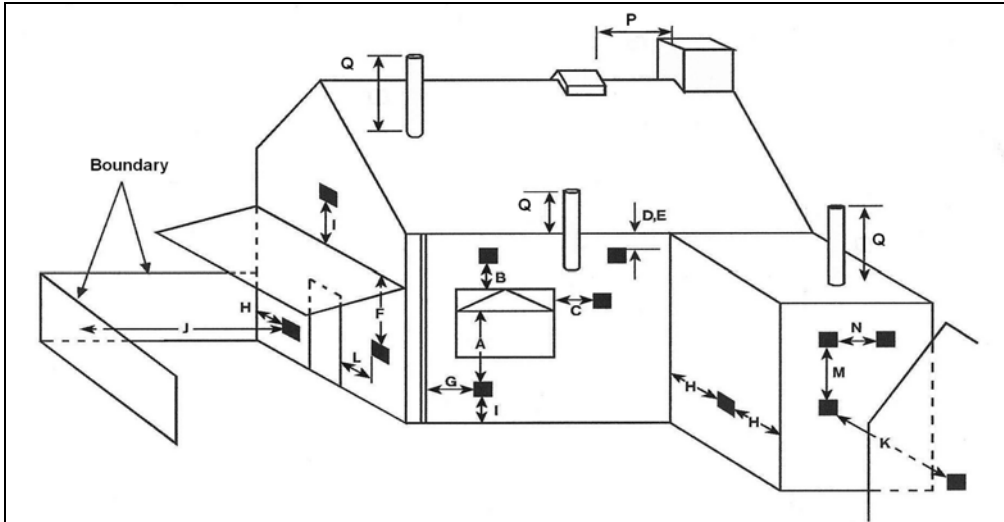

TERMINAL POSITION	MIN DISTANCE
A <sup>(1)</sup> - Directly below an opening window or other opening, eg air brick	300mm
B <sup>(1)</sup> - Directly above an opening window or other opening, eg air brick	300mm
C <sup>(1)</sup> - Horizontally to an opening window or other opening, eg air brick	300mm
D - Below gutters, soil pipes or drain pipes	75mm(2)
E - Below eaves	200mm(2)
F - Below balconies or car port roof	Not allowed
G - From a vertical drain pipe or soil pipe	150mm(2)
H - From an internal or external corner or to a boundary alongside the terminal	300mm
I - Above ground, roof or balcony level	300mm
J - From a wall, fence, building or boundary line facing the terminal	2500mm
K - From a terminal facing a terminal	2000mm
L - From an opening in a car port (eg door, window) into a dwelling	Not allowed
M - Vertically from a terminal on the same wall	1500mm
N - Horizontally from a terminal on the same wall	300mm
P - From a vertical structure on the roof	500mm
Q - Above intersection with roof	300mm

#### NOTES

- (1) In addition, the terminal should not be nearer than 150mm to an opening in the building fabric formed for the purpose of accommodating a built-in element such as a window frame.
- (2) Minimum distance is reduced to 25mm from a terminal guard.
- (3) Terminals must be sited above 2.1m from ground for walkway or patio; also for car parking area less than 2.5m from terminal.

The flue terminal must be sited with minimum clearance distances as shown in the diagram.

A terminal guard must be fitted if the terminal is sited less than 2m above ground level, or above a balcony, or accessible flat roof.

Where the flue terminates within 1m of a plastic or painted gutter or within 500mm of painted eaves, then protection should be provided in the form of an aluminium shield at least 1m in length, fitted to the underside of the gutter or painted surface.

#### Please Note!

Due to the low flue gas temperature, 'pluming' will occur at the flue terminal. Care should be taken to ensure that the discharge plume will not cause annoyance to the customer or neighbours. It is generally recommended that flues should discharge vertically at roof level. In this position, pluming is not normally a problem.

### 5.4.2 Flue system

The flue system must be installed in accordance with BS5440:1 and the Building Regulations. **Horizontal flue pipe runs must always be installed with a minimum slope of 50 mm/metre towards the boiler.** This will prevent condensation from gathering in the flue pipe, and will also reduce the chance of icicles forming over horizontal pipe ends in the Winter.

## Note regarding internal air-flue systems.

It is recommended that the boiler is sited on or next to an external wall so as to negate the need to use a void or enclosure as a route for the flue system. Where this is not possible the following applies:

CORGI have issued a Guidance Document on the safe installation of flue systems within a dwelling. This is a Technical Bulletin reference TB200, and can be downloaded from the internet. In brief this requires the air-flue system to be **\*accessible for visual inspection\*** by a service engineer. Particular concern focuses on the joints, supports, material and correct slope of the flue installation, which should all be in accord with the instructions given in this document and with good practice. We recommend that the guidance given in this document is adhered to, especially in the case of twin pipe flue systems.

## 5.5 Flue discharge and air supply

A number of different flue systems are available from Atmos for use with this appliance:-

- 60/100mm concentric system, comprising a standard through the wall flue kit or an extended system.
- 80/125mm concentric system.
- 80mm twin pipe system which enables separate air intake and flue pipes to be fitted to the appliance.
- 80mm PPS and 50mm Mupvc plastic twin pipe system for special applications.

Maximum lengths are specified in § 5.6.4 to 5.6.7, and must not be exceeded.

Other special flue arrangements covering Prefabricated Chimneys and Multi Storey flue systems are included in § 5.7 to 5.9.

### 5.5.1 60/100mm Concentric Standard through the wall Horizontal Terminal

#### **IMPORTANT!**

Using the concentric adapter set (see photo), the standard two-pipe connection can be changed into a concentric connection.

1. Seal the open air supply connections in the appliance with the sealing cap delivered with the set (item C in photo).
2. Remove the sealing ring around the flue discharge in the appliance, as shown below.
3. In its place, fit the sealing ring  $\varnothing 116 \times 110$  mm (item B in photo).
4. Fit the adapter (item A in photo) on the flue discharge.

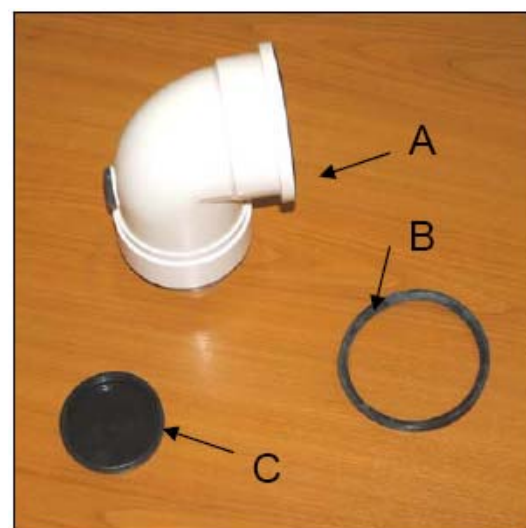
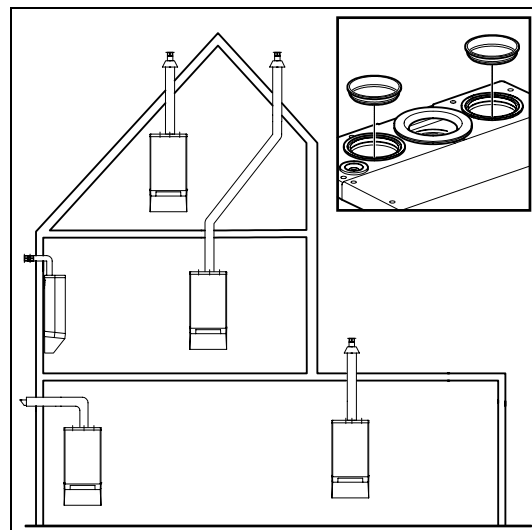
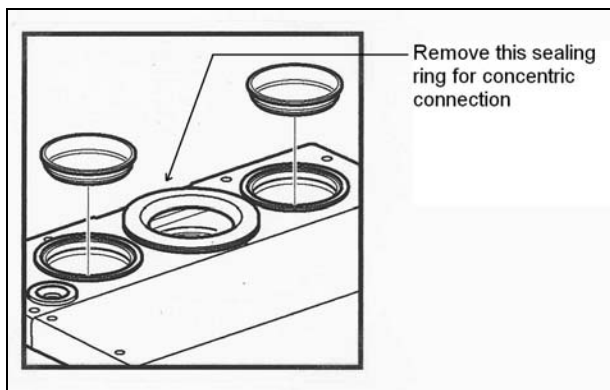



### Mounting 60/100mm horizontal concentric terminal

1. Drill hole of diameter 110 mm or larger hole.
2. Cut the terminal to the length required.
3. Slide the terminal into the opening and fit rosettes to cover the opening.
4. Ensure the pipes slope back to the appliance.

An alternative telescopic 60/100 horizontal concentric terminal is available from Atmos. The flue should be adjusted to length and the supplied sealing tape applied.  
**NOTE :** Atmos also provide anti-plume kits for use with the telescopic flue system.

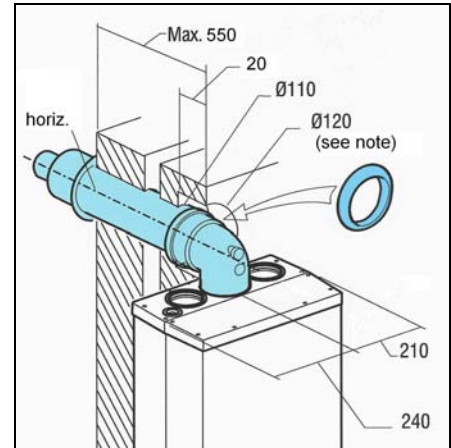

**Note:** Mark centre of hole on wall at 100mm above the top of the boiler.

### 5.5.2 60/100mm Concentric extended flue system

Refer to the Atmos Price List for the full list of flue components.

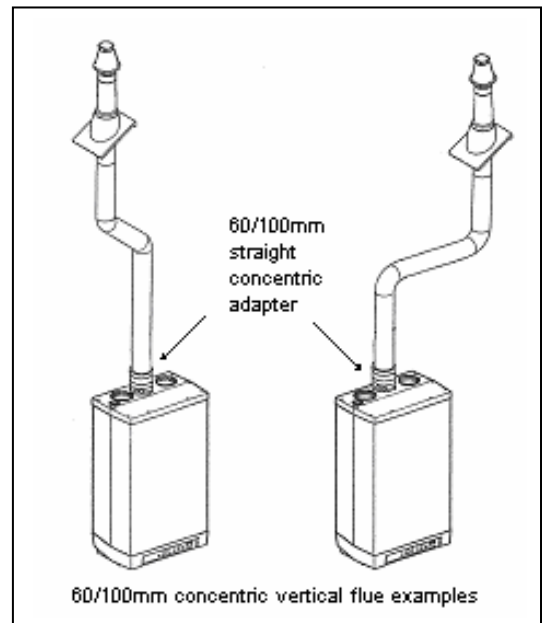
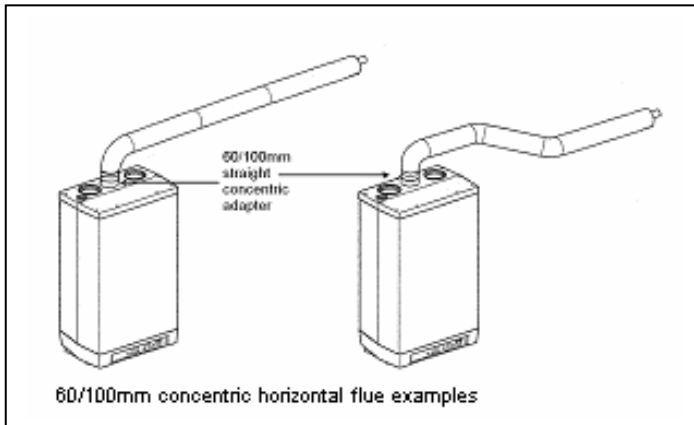
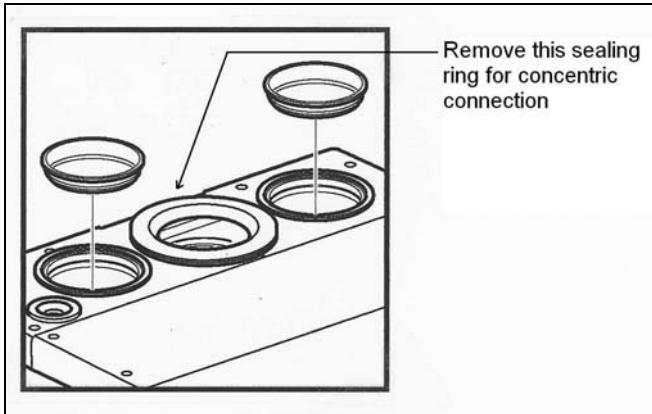

Table of Atmos 60/100mm concentric flue equivalent lengths

Maximum equivalent concentric length allowed is 10 metres (Note: Includes an allowance for the terminal; ie the terminal can be ignored from the equivalent length)		
60/100mm concentric components	Equivalent concentric length (M)	Remarks
45° bend	1.5	
87° bend	3.0	



### 5.5.3 Vertical Concentric connection

Straight adapters are available for either 60/100mm or 80/125mm systems.

**IMPORTANT!**

Using the concentric adapter set (see photo), the standard two-pipe connection can be changed into a concentric connection.

5. Seal the open air supply connections in the appliance with the sealing cap delivered with the set (item C in photo).
6. Remove the sealing ring around the flue discharge in the appliance, as shown above.
7. In its place, fit the sealing ring  $\varnothing 116 \times 110$  mm (item B in photo).
8. Fit the adapter (item A in photo) on the flue discharge.

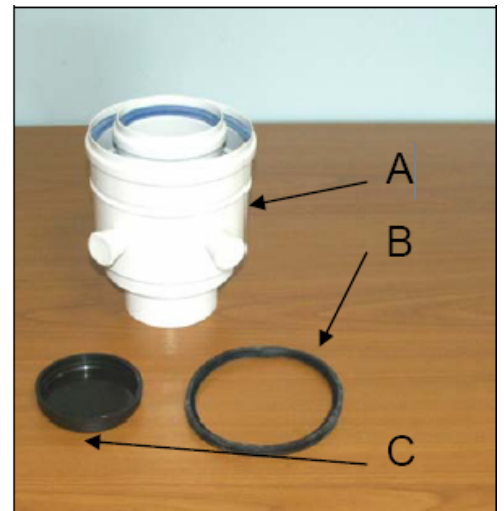

### 5.5.4 80/125mm Concentric flue system

Refer to the Atmos Price List for the full list of flue components.

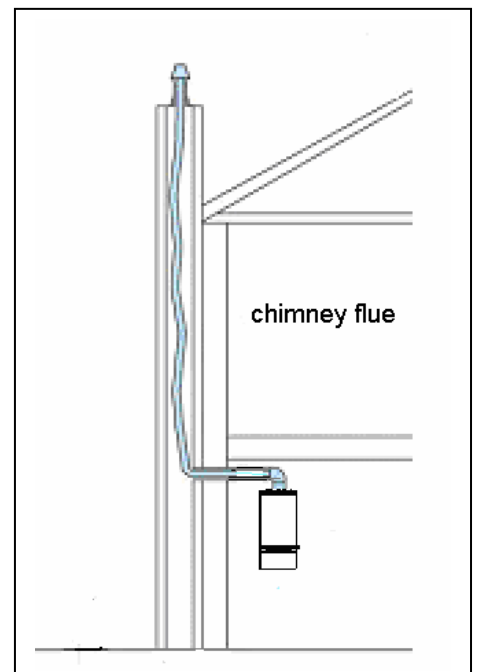
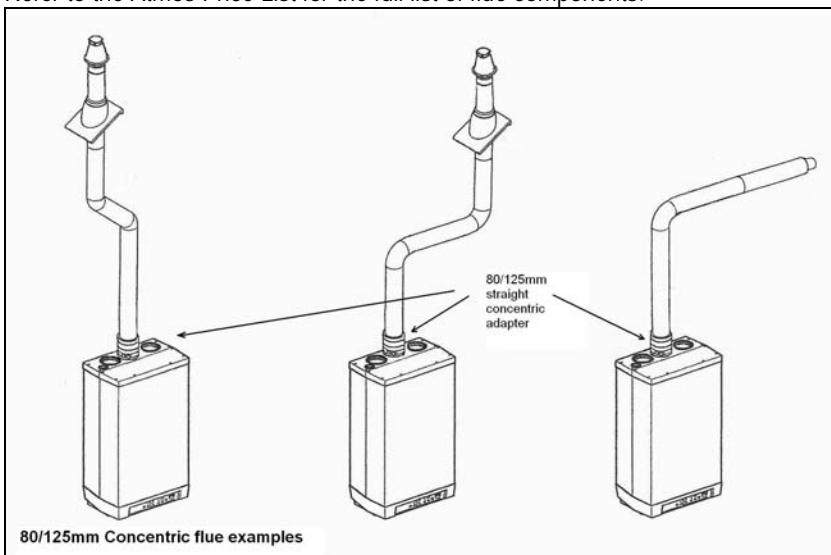

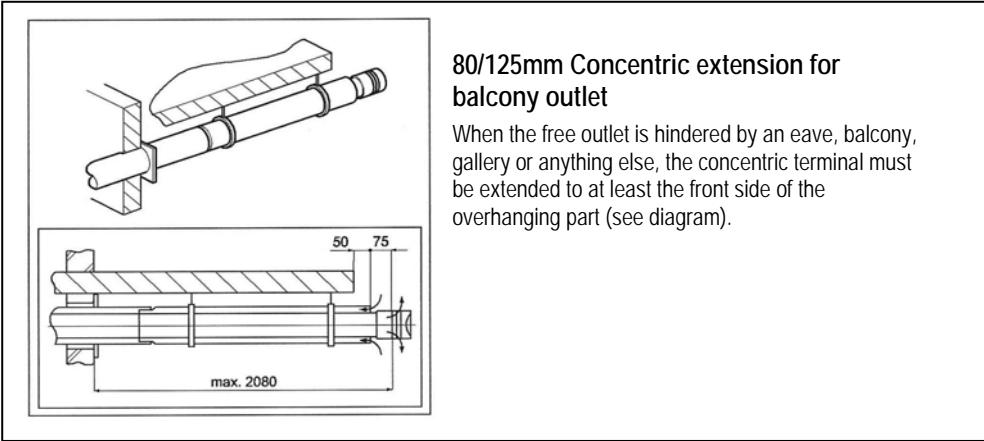

**80/125mm Concentric extension for balcony outlet**

When the free outlet is hindered by an eave, balcony, gallery or anything else, the concentric terminal must be extended to at least the front side of the overhanging part (see diagram).

Table of Atmos 80/125mm concentric flue equivalent lengths

Maximum equivalent concentric length allowed is 27 metres (Note: Includes an allowance for the terminal; ie the terminal can be ignored from the equivalent length)		
80/125mm concentric components	Equivalent concentric length (M)	Remarks
45° bend	1.5	
87° bend	3.0	

**5.5.5 Twin-pipe connection**

9. When using the right-hand air supply, the sealing cap must be moved to the left-hand air supply.
10. Locate the pipes for the air supply and flue discharge in the supply and discharge stubs. The in-built silicone sealing ring provides an airtight connection.

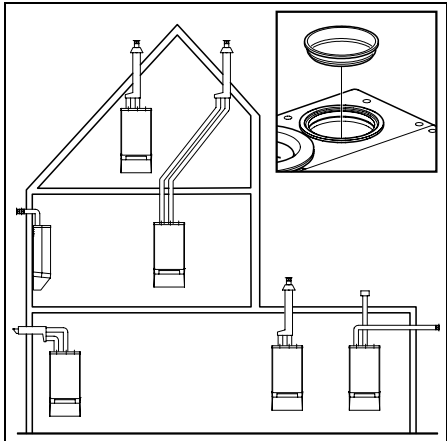

### 5.5.6 80mm twin pipe flue system

Refer to the Atmos Price List for the full list of flue components.

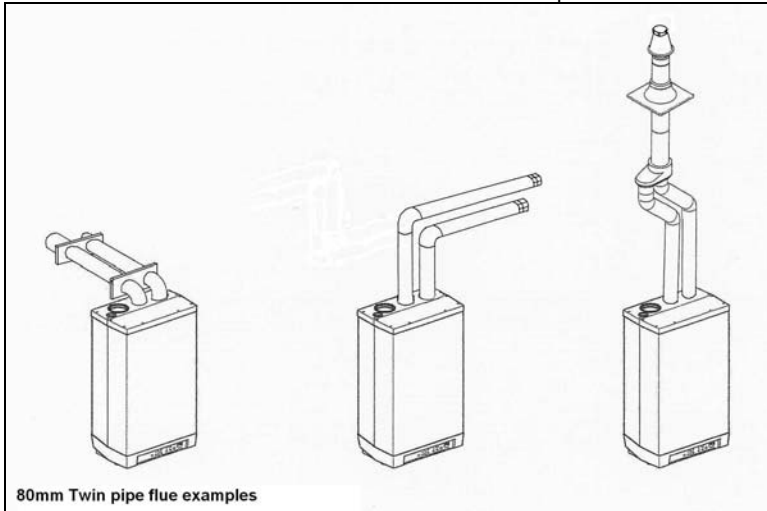

#### Terminal

The flue discharge at the terminal must be at least 75mm in front of the air intake and the distance between the two pipes at least 75mm.

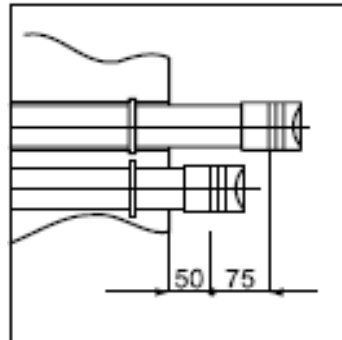
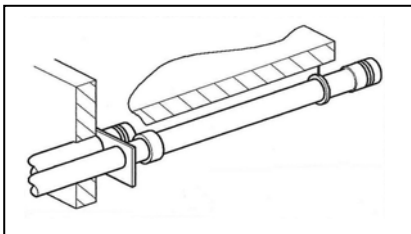

#### 80mm Twin pipe extensions for balcony outlet

When the free outlet is hindered by an eave, balcony, gallery or anything else, the air supply pipe and the flue discharge pipe must be extended to at least the front side of the overhanging part. (In this case the flue discharge must be extended 75mm further than the air supply pipe inlet).

When the air supply is not disturbed by obstacles, such as a separating wall, and when the outlet is not at the edge of a building, the air supply pipe does not need extension (see diagram).

Table of Atmos 80mm twin flue equivalent lengths

Maximum total length allowed is 60 metres (ie Equivalent length of supply pipe + Equivalent length of flue discharge pipe) (Note: Includes an allowance for the terminal; ie the terminal can be ignored from the equivalent length)		
80mm components	Equivalent length (M)	Remarks
45° bend	1.5	
87° bend	3.0	



---

### 5.5.7 Plastic twin pipe flue systems

**NOTE** Consult Atmos for these systems. Use of non-approved flue systems will invalidate the guarantee. For special applications, the appliance can be used with plastic flue pipes, which are available from Atmos as follows:

**PPS.** This is a rigid translucent plastic pipe in 60mm and 80mm diameters, together with a range of fittings. This is suitable for continuous use at 120°C and is therefore suitable for connection from the appliance to the flue terminal. This must include the 80mm PPS pipe with flue gas test point, which is required for commissioning of the boiler.

**PPS Flexible.** This is a flexible pipe 80mm diameter which can be used for chimney linings, or for difficult vertical runs. Note that it must only be used vertically and **MUST NOT** be used for horizontal runs because the condensate will accumulate and could block the flue path.

**Plastic combustion air inlet systems:** All plastic pipes can be used for air inlet. The pipe does not need to slope since there is no condensate.

**NOTE:** In longer runs of 80mm plastic flue pipe – 3m long or longer – it is advisable to fit a condensate drain in the flue pipe to facilitate the draining away of condensate before it reaches the aluminium parts of the flue system or the boiler itself. This is to prevent excessive corrosion. Atmos can supply a condensate drain-off fitting for 80mm flue pipe. It incorporates a flue test point and it needs to be fitted into a vertical section of the flue. The condensate drain-off fitting allows connection to solvent weld overflow pipe. A trap must be fitted into the condensate drain to prevent flue gases escaping.

## 5.6 Roof outlet prefabricated chimney

Appliance category: C33

When there is little space in a shaft, a roof outlet through a prefabricated chimney may be necessary.

The prefabricated chimney must comply with the minimum lengths shown. The supplier must guarantee the proper operation of the prefabricated chimney with respect to wind attack, ice formation, rain ingress, etc.

In view of the different models and requirements, the prefabricated chimneys must be adjusted to the local situation: a gas certificate is not required.



### CAUTION

The connection of the air supply and the flue discharge between the appliance and the prefab chimney must be made in pipes of diameter 80 mm.

### Maximum pipe length

See §5.5.5

### Mounting of prefabricated chimney

The outlet can be made at any place in the pitched or flat roof surface.

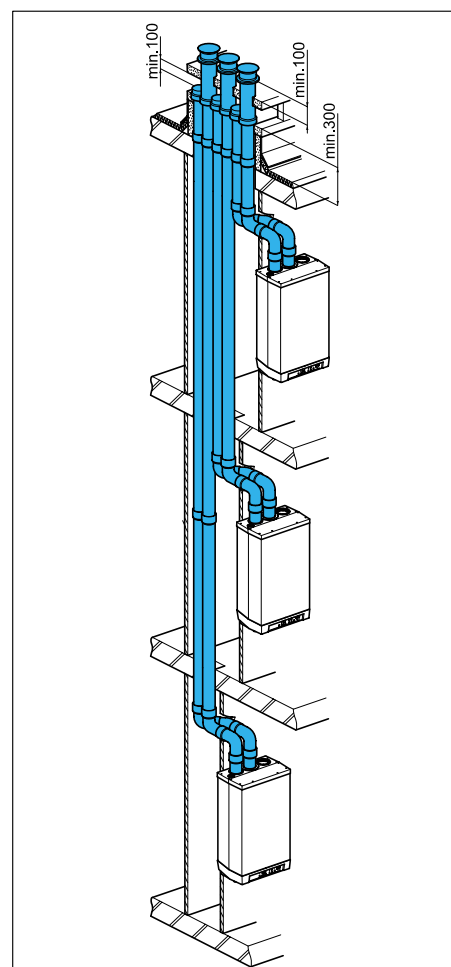

## 5.7 Atmos MS System

Appliance category: C53 (individual vertical flue and separate horizontal air inlet).



### CAUTION

The air supply (A) in the outside wall must be provided with an Atmos inlet grid.

Flue terminals (B) can be individual, or common terminals can be provided for groups of up to 6 flues.

### Maximum pipe length

See §5.6.5. The air supply pipes and flue discharge pipes should be 80mm.

### Mounting of air supply - horizontal

The air supply (A) can be made at any place in the outside wall.

1. Make an opening of diameter 90 mm at the place of the supply.
2. Shorten the air supply pipe to the correct length out of the wall.
3. Mount the Atmos inlet grid and attach this to the pipe.
4. Slide the air supply pipe into the opening and cover the opening with a rosette, if necessary.

### Mounting flue terminal - vertical

1. Mount a roof tile with shell in a pitched roof surface at the place of the outlet.  
Mount an adhesive plate suitable for a double-walled flue terminal diameter 80 mm (outside diameter 96 mm) in a flat roof.
2. Slide the double-walled flue terminal from the outside to the inside through the roof terminal.  
The outlet must protrude at least 500 mm above the roof surface.

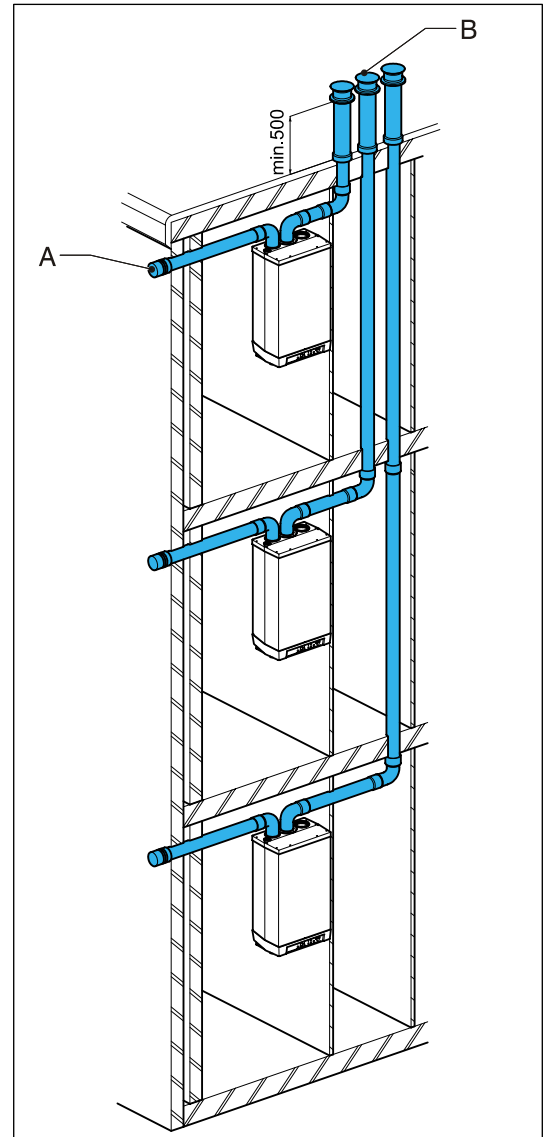

## 5.8 Atmos Communal Flue System (CFS)

A design service is provided for each application. There are different configurations possible and the main ones are illustrated.

CFS-NV Naturally ventilated, working under negative pressure

CFS-FA Fan assisted, working under positive pressure – smaller diameter pipes are used

### 5.8.1 Atmos CFS<sup>EO</sup> – FA System

Appliance category: C83 (Communal Flue System, Exhaust (Flue) Only – Fan Assisted)

An air supply from the outside wall and a roof outlet with common discharge system is allowed. The system is fan assisted positive pressure.

**A non-return valve arrangement on each boiler is essential to prevent recirculation of exhaust gases to non operational appliances.** There is a common condensate collector at the base of the flue system which must be taken to a suitable drain.

#### Maximum pipe length

The maximum length of the air supply and flue discharge pipes between appliance and common flue discharge and air supply together is 75 metres (80mm pipes).

#### Common flue discharge

The outlet of the flue discharge can be made at any place in the pitching roof surface, provided that the outlet in the roof surface has the same orientation as the air supply in the outside wall. With a flat roof the outlet of the flue discharge must be made in the 'free' outlet area.

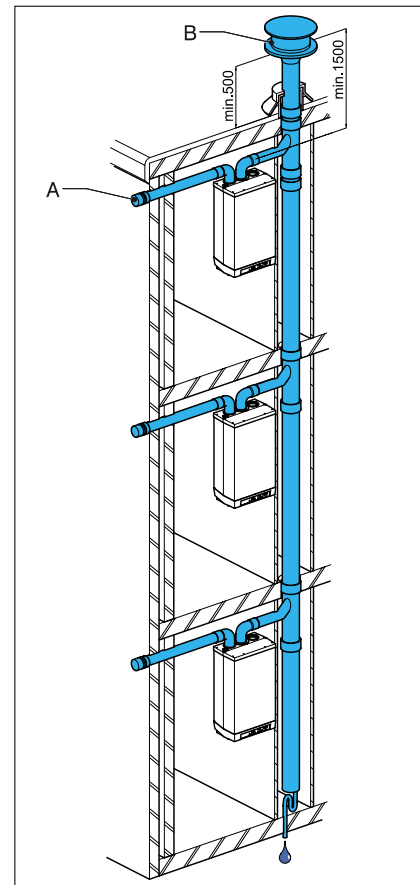

### 5.8.2 Atmos CFS System

Appliance category: C43

CFS – NV or CFS – FA systems are available. The fan assisted positive pressure system allows a more compact installation. Connection from the appliance can be either twin pipe or concentric. There is a common condensate collector at the base of the flue system which must be taken to a suitable drain.

CFS – FA systems require a non-return valve arrangement on each boiler, which is essential to prevent recirculation of exhaust gases to non operational appliances.



#### CAUTION

For the common flue discharge cover and air supply cover a certificate of incorporation from the Gastec-Gasinstituut is required.

#### Maximum pipe length

The maximum length of the air supply and flue discharge pipes between appliance and CFS system together is 75 metres (80mm pipes).

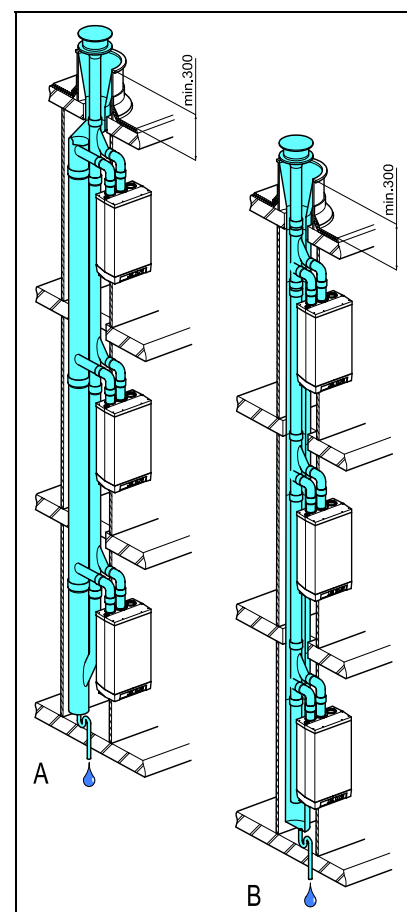



## 6. COMMISSIONING

### 6.1 Fill and de-aerate the appliance and the system



#### WARNING

Connect the appliance to the mains voltage only after filling and de-aerating!

#### 6.1.1 CH system



#### WARNING

All new and existing systems must be thoroughly drained and flushed out in accordance with BS7593 requirements. A suitable cleaning agent is Sentinel X400, following the manufacturer's instructions. A corrosion inhibitor should be added and the concentration level checked. The inhibitor should be suitable for the materials used in the appliance, such as copper, brass, stainless steel, steel, plastic and rubber. A suitable product is Sentinel X100, following the manufacturer's instructions.

1. Use the filling loop to fill the system to a maximum pressure of 1 to 2 bar with a cold system.
2. De-aerate the appliance with the manual air vent (A in diagram). Alternatively, an automatic air vent can be mounted to the appliance instead of the manual air vent.  
**Note: When the appliance is located at, or near to, the top of the system (eg in a loft), an automatic air vent should be fitted.**
3. Vent each radiator and purpose fitted air vent in turn starting with the lowest in the system. The system pressure should be regularly monitored during this process and topped up when required.
4. Air should be vented from the appliance pump by opening the pump's vent plug and allowing water to bleed for a few seconds.  
**Note: Take care that the water does not splash onto the electric parts (eg controller and terminals).**
5. Check all joints for leaks.
6. **Fill the condensate trap with water – important (see diagram).**

#### 6.1.2 Gas supply

1. Purge the gas supply if necessary via the inlet pressure measuring nipple on the gas valve.
2. Check the connections for leaks.
3. Check the inlet pressure. See Gas and air control.

#### Note

The appliance must be installed and commissioned in accordance with the manufacturer's instructions in order to comply with the Building Regs. To demonstrate compliance, the Benchmark Checklist (located at the back of this Manual) should be completed and signed at the time of commissioning, and left with the customer.

**Failure to flush and add inhibitor to the system will invalidate the Appliance Warranty.**

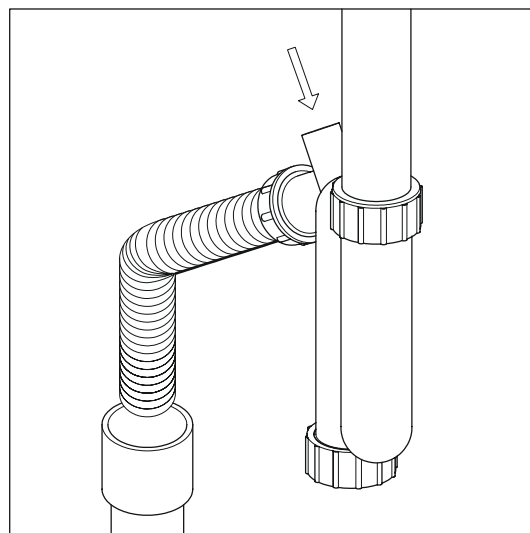
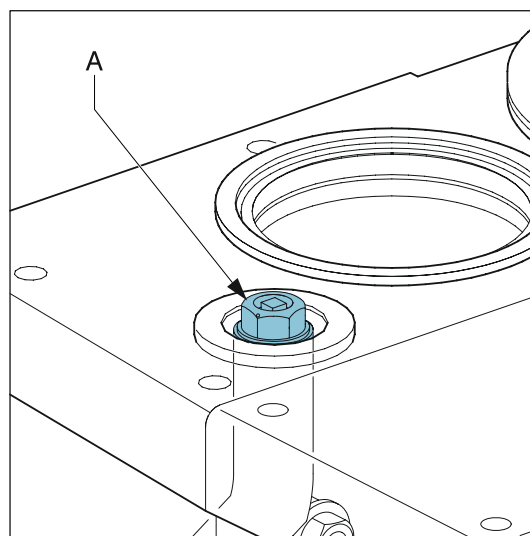

## 6.2 Commissioning of the appliance

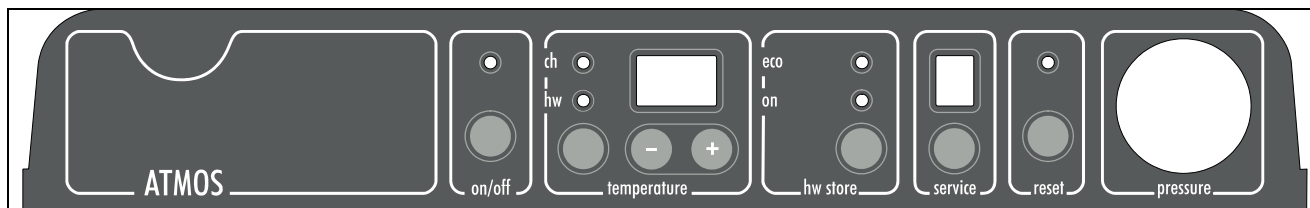

After having carried out the above operations, the appliance can be commissioned.

1. Switch on the electrical supply to the appliance.  
The appliance may carry out a self-test as determined by the controller:  
[2] (on service display).  
After completing the self-test, a horizontal mark will appear in the service display: [-].
2. Press the on/off button in order to put the appliance into operation.  
The boiler is heated and on the service display appear [3], [4], [7].
3. Set the pump position on the basis of the set maximum power and the resistance of the system on the water side. For the head of the pump and the pressure loss of the appliance, see § 7.5.
4. Set the room thermostat higher than the room temperature. The appliance will now switch to CH operation: [5] on service display.
5. Heat the system and the appliance to about 80°C.
6. Check the temperature difference between the supply and return of the appliance and the radiators. This should be about 20°C. At this stage set the maximum power on the service panel. See Setting of maximum power. If necessary, change the pump position and/or the radiator valves. The minimum flow-through is:-
  - 200 l/h at a set power of 7.0 kW
  - 750 l/h at a set power of 26.2 kW
7. Switch off the electrical supply to the appliance.
8. De-aerate the appliance and the system after cooling down. (fill up if necessary)
9. Check the heating system for proper operation.
10. Instruct the User about filling, de-aerating and the operation of the heating system.

### Note

The controls on the display for 'hw' are not applicable for the HE26 appliance.

### Remarks

- The appliance has been provided with an electronic controller that ignites the flame and continuously monitors this at each heat demand from the heating system.
- The circulation pump starts running at each heat demand of the boiler. The pump has an overrun time of 1 minute. The overrun time can be changed if necessary. See Installer settings.
- The controller will automatically run the pump for 10 seconds, once every 24 hours, to prevent it from getting stuck. This activation of the pump takes place at the time of the last heat demand 24hrs later. In order to change this time, set the room thermostat higher for a while at the desired time.
- Step modulation is set to function (factory setting) so that the power/speed is increased gradually from the minimum (parameter c). This provides the best CH operation. However if the appliance is being used only for heating an indirect hot water tank or for heating fan convectors, the step modulation can be turned off. The appliance will then start almost immediately at the maximum setting and the system will heat up faster.

## 6.3 System Shutdown



### CAUTION

Drain the appliance and the system when the mains voltage has been disconnected and there is a chance of freezing.

1. Drain the appliance using the drain tap.
2. Drain the system at the lowest point.

### 6.3.1 Frost protection

- In order to avoid freezing of the condensate discharge pipe, the appliance should be installed in a frost-free room.
- In order to avoid freezing of the appliance (heat exchanger), it has an appliance frost protection. When the temperature of the heat exchanger drops to 5°C, the burner will be activated and the pump will start running until the temperature of the heat exchanger reaches 10°C.
- When the system (or a part thereof) can freeze, a frost thermostat should be installed in the area to be protected. Connect this according to the wiring diagram. See § 10.1.

#### Note!

The external frost thermostat is not active when the appliance has been switched off at the operating panel or when the mains voltage has been interrupted.

## 7. SETTING AND ADJUSTMENT

The functioning of the appliance is mainly determined by the (parameter) setting in the appliance controller. A part of this can be set directly via the operating panel, while another part requires an Installer code to be entered before settings can be changed.

### 7.1 Directly via operating panel

The following settings can be made directly via the operating panel.

#### Appliance on/off

The appliance is activated by means of the *On/Off* button.

When the appliance is working, the green LED will be lit. When the appliance is off, one bar on the service display () is shown to indicate the presence of voltage.

#### Adjustment of CH supply temperature

Press the *Temperature* button for approx 2 secs until the LED CH and the display start to flash (the display shows the set temperature). Change the temperature using the "+" and "-" buttons, adjustable between 30°C and 90°C.

Press the *Reset* button to store the changes (or press the *On/Off* button to close the menu without storing the changes).

Note: After 30 seconds of no action, the changes will automatically be stored and the controller will return to normal.





#### Reset button

When the controller detects a fault, the red fault LED flashes (above the *Reset* button) and a fault code is shown on the *Temperature* display. (Note: On appliances produced before Nov 07, the red LED is lit and a flashing fault code is shown in the service display). The appliance can be restarted by pressing the *Reset* button for 5 seconds. Check the nature of the fault by means of the fault codes under §8 and solve the problem, if possible, before resetting the appliance.

### 7.2 Settings through the service code

The controller of the appliance has been set in the factory according to the parameters of § 7.3.

These parameters can only be changed with the service code. Proceed as follows to activate the program memory:-

1. Set the appliance in the off mode using the *On/Off* button () on the service display).
2. Simultaneously press the *Service* and *Reset* buttons, until a  appears on the service and the temperature displays.
3. Using the "+" and "-" buttons, set  (service code) on the temperature display.
4. Use the "*Service*" button to set the required parameter on the service display.
5. Using the "+" and "-" buttons, adjust the parameter to the required value on the temperature display.
6. After having entered all required changes, press the "*Reset*" button until  appears on the service display (until  appears on the service display for appliances produced before Nov 07).
7. Switch on the appliance again using the "*On/Off*" button.

The controller has now been reprogrammed.

**Note:** By pressing the *Temperature* button, the factory settings of the parameters are restored (can only be done if the service code has been set).

### 7.3 Parameters

Parameter	Setting	Factory setting	Description
		InterSystem HE 26	
0	Service code [15]	-	Access to installer settings. The service code must be entered (=15).
1	System type	1	0 = standard 1 = heating only operation + indirect hot water tank <b>(Note: Factory setting is 1. Do not change this setting)</b> 2 = n/a 3 = n/a
2	CH pump continuous	0	0 = pump normal with overrun 1 = pump on continuously; 2 = n/a
3	Set CH power	50	Setting maximum CH load, range c – 99% (or 100 if button pressed again when 99 reached)
4	Set max power	50	Setting maximum power (can be increased to 99)
5	Min. supply temperature of the control line	25	Setting range 10°C to 25°C (Weather-dependent control)
6	Min. outside temperature of the control line	-7	Setting range -9°C to 10°C (Weather-dependent control)
7	Max. outside temperature of the control line	25	Setting range 10°C to 30°C (Weather-dependent control)
8	CH pump overrun time after CH operation	1	Setting range 0 - 15 minutes
9	CH pump overrun time after external HW tank operation	2	Setting range 0 - 15 minutes (n/a)
A	Position of three-way or two-way valve	0	0 = output signal given for CH operation (n/a) 1 = output signal given for HW tank operation (n/a)
b	(n/a)		
C	Step modulation	1	0 = step modulation off during CH operation 1 = step modulation on during CH operation
c	Min speed in CH operation	25	Setting range 25 to 50% of fan speed (Note: For propane or for appliances with flue non-return valve, set 40)
d	(n/a)		
E	Min. supply temperature during OT demand	10	Setting range 10°C to 60°C. (OT = OpenTherm stat)
E.	OT response	0	0 = Ignore the OT demand if it is lower than parameter E 1 = Set the value at parameter E, if the OT demand is lower 2 = OT device is switched off and the room stat functions as an on/off switch, with the supply temp set at the appliance.
F	Starting speed CH	70	Setting range 50 to 99% (Note: For propane, set 50). This parameter sets the fan speed for ignition and post purge.
F.	Starting speed DHW (not applicable to InterSystem)	70	Setting range 50 to 99% (Note: For propane, set 50). This parameter sets the fan speed for ignition and post purge
h	Max. fan speed	45	Setting range 40 to 50 (40 = 4000 rpm, 50 = 5000 rpm) The absolute maximum speed can be set through this parameter.
n	(n/a)		
o	Heating delay after hw use	0	(n/a) (0 to 15 mins).
P	Minimum switch off time during CH operation	5	Setting range 0 to 15 minutes (anti cycling function)

## 7.4 Setting maximum CH power

The maximum CH power is set to 50% in the factory. When the CH system requires more or less power, the maximum CH power can be changed by adjusting the fan speed. See table: Setting CH power.

This table gives the relation between the fan speed and the appliance power.

### Setting CH power

Required CH power (approx kW)	Setting on service display (% of the maximum speed)
26.2	83
23.5	75
21.9	70
20.4	65
18.9	60
17.4	55
15.8	50
14.2	45
12.7	40
11.1	35
9.5	30
8.0	25

#### Caution

The power slowly increases while burning (modulation by time) and decreases as soon as the set supply temperature is reached.

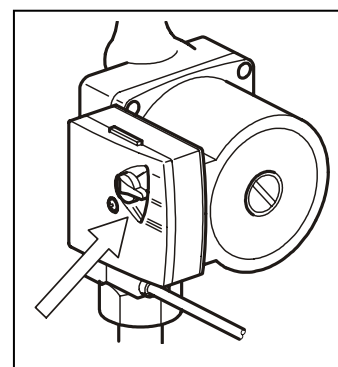

## 7.5 Setting pump position

The switch for setting the pump position is located on the connecting box of the CH pump

1. Set the pump position on the basis of the set maximum power and the resistance of the system on the water side. See diagram: Pressure loss and pump lift, type Ups 50-130, positions 1, 2 and 3.
2. Check the temperature difference between the supply and return of the appliance: this should be about 20°C.

The minimum flow-through	Set power
200 l/h	7.0 kW
750 l/h	26.2 kW

- A. (Not applicable)
- B. InterSystem HE26
- I. Pump position 1
- II. Pump position 2
- III. Pump position 3
- X. Flow-through in litres/hr
- Y. Pressure loss / pump lift in metres head

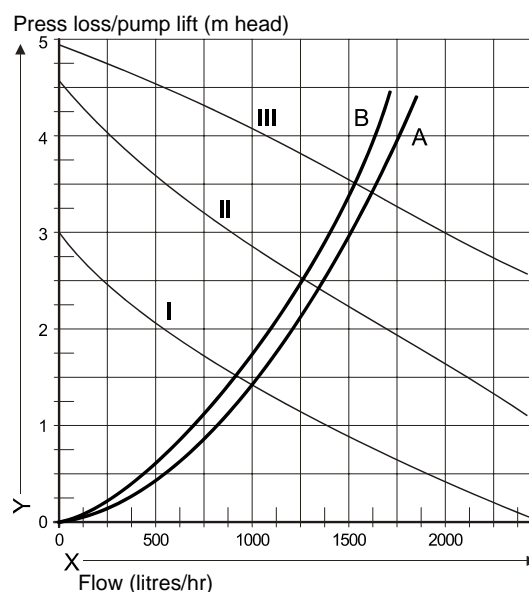

## 7.6 Weather-dependent control

When the outside sensor is connected, the supply temperature is automatically controlled dependent on the outside temperature in accordance with the set control line.

The  $T_{set\ CH}$  (= CH supply temperature) is set via the temperature display. If required, the control line can be adjusted by the service code. See § 7.3.

- X.  $T_{outside}$  °C
- Y.  $T_{supply}$  °C
- A. factory setting
- B. example

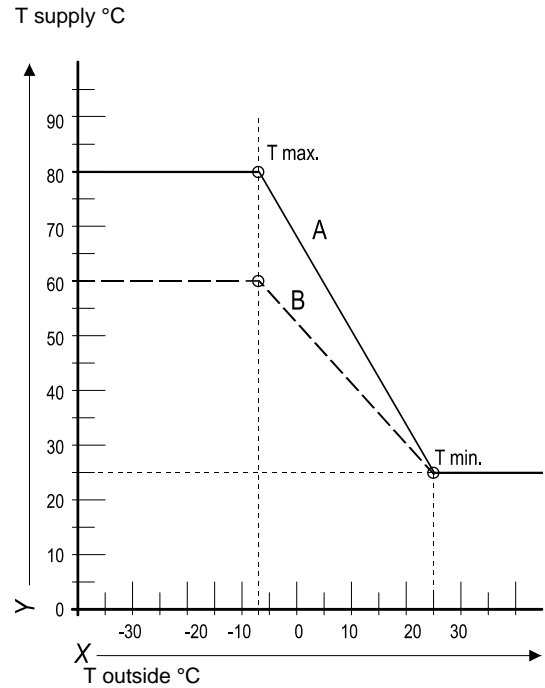

## 7.7 Conversion to other gas type



### CAUTION

Activities on the gas-containing parts should only be executed by a qualified registered installer.

When the appliance is connected to another gas type than the type for which the manufacturer has set the appliance, the gas setting ring must be replaced. Conversion sets for other gas types can be ordered.

### Conversion of the gas setting ring

1. Switch off the electrical supply to the appliance.
2. Close the gas tap.
3. Remove the front cover of the appliance.
4. Disconnect the coupling (1) above the gas valve and turn the gas mixing pipe (2) backwards.
5. Replace the O-ring (3) and the gas setting ring (4) by the rings of the conversion set.
6. Reassemble in reverse order.
7. Open the gas tap.
8. Check the gas connections for tightness/ leaks.
9. Switch on the electrical supply to the appliance.
10. Change the parameters c and F to the values given in the table.
11. Now check the setting of the gas/air ratio. (See below)
12. Attach a sticker of the set gas type over the existing sticker on the gas mixing pipe (2).
13. Apply a sticker of the set gas type at the appliance plate.
14. Remount the front cover of the appliance.

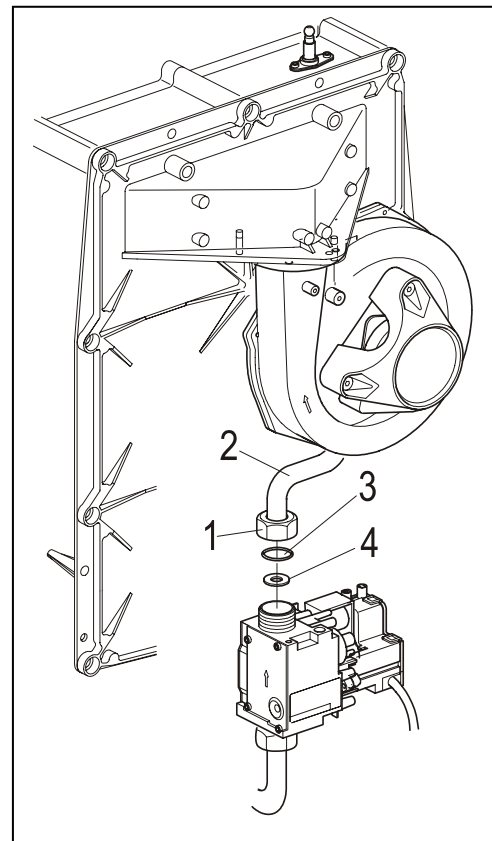

## 7.8 Gas-air control

The gas-air control is set in the factory and normally does not need any adjustment.

The setting can be checked by measuring the  $CO_2$  percentage in the flues or by measuring the pressure difference.

In case of any alterations, replacement of the gas valve or conversion to another gas type, the control must be checked and reset if necessary

according to the table below:-

Gas type	Natural gas H	Propane P
Gas category	2H G20	3P G31 (propane)
CO <sub>2</sub> % at low position (L) (service and -)	8.8 – 9.2	9.3 – 9.7
CO <sub>2</sub> % at high position (H) (service and +)	8.6 – 9.6	9.5 – 10.5
Gas inlet pressure dynamic (mBar)	17-25	25-45
Gas inlet pressure static (mBar)	20	37
Gas setting ring diameter (mm)	6.95	5.35
Minimum speed (% of max) (parameter c)	40	40
Min. starting speed (% of max) (parameter F)	70	50

## 7.9 Setting gas-air control

### Setting by measuring the CO<sub>2</sub> content of the flue gases

#### Remark

- A CO<sub>2</sub> measuring nipple must be mounted right above the appliance in the flue discharge.
- A. Dust cap (socket head wrench torx T15)
  - B. Setting screw for the low position (socket head wrench torx T15)
  - C. Off-set pressure measuring nipple
  - D. Inlet pressure measuring nipple
15. Switch off the appliance using the *On/Off* button (  on service display).
  16. Open the flue gas measuring nipple and connect the measuring hose.
  17. Switch on the appliance using the *On/Off* button.
  18. Set the boiler to the lowest output by simultaneously pressing the "Service" and "-" buttons on the operating panel until an  appears on the service display.
  19. Measure the CO<sub>2</sub> value. If the CO<sub>2</sub> value does not correspond with the value in the table, proceed as follows for setting:-
  20. Remove the front cover of the appliance.
  21. Remove the dust cap (A) with a torx T15 driver
  22. Using a torx driver (T15), adjust the setting screw (B) to the correct CO<sub>2</sub> value (clockwise higher and counter-clockwise lower).
  23. After measuring and setting, set the boiler to the highest output by simultaneously pressing the "Service" and "+" buttons (twice) on the operating panel until an  appears on the service display.
  24. Measure the CO<sub>2</sub> value. Check that the CO<sub>2</sub> value corresponds with the value in the table.
  25. If the high output CO<sub>2</sub> is not within the parameters allowed in the chart above, return to low output and adjust the CO<sub>2</sub> setting at low output before returning to high out put to check it again. Contact the manufacturer if you encounter difficulties.
  26. Measure the CO/CO<sub>2</sub> ratio, (see § 7.10)
  27. Exit the test mode by simultaneously pressing the "+" and "-" buttons on the operating panel. Replace the dust cap (A) and close the flue gas measuring nipple.
  28. Remount the front cover of the appliance.

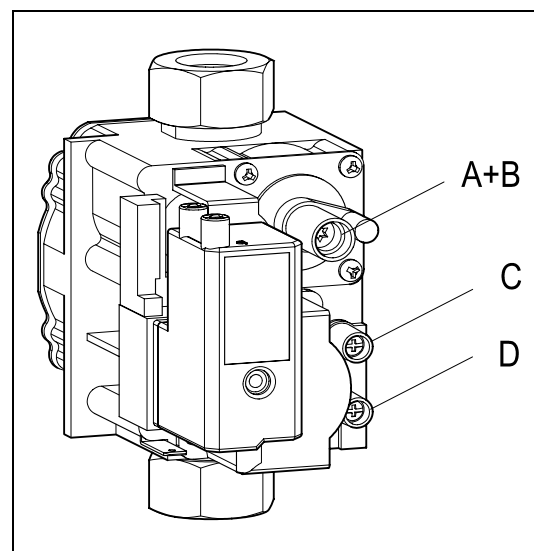

Siemens gas valve & ignition transformer







**Caution:** Check the measuring nipples used for gas tightness.

**Caution:** On windy days or on installations with a long flue run it is necessary to replace the front cover of the boiler in order to obtain an accurate CO<sub>2</sub> measurement

### Setting the gas valve by pressure measurement



This method is less accurate, but usually gives a sufficient result.

29. Switch off the appliance using the *On/Off* button (  on service display).
30. Remove the front cover of the appliance.
31. Turn the measuring nipple (C) on the gas valve open with two turns and connect this through a tube to the plus connection of the pressure gauge.
32. Switch on the appliance using the *On/Off* button.
33. Set the boiler to the lowest output by simultaneously pressing the "Service" and "-" buttons on the operating panel until an  appears on the service display.
34. Read the pressure. This should be about -5 Pa or -0.05 mBar (min. -10 Pa, max. 0 Pa. or min. -0,1 mBar, max. 0 mBar). When this is not the case, proceed as follows for setting:-
35. Remove the dust cap (A) with a torx T15 driver.
36. Set the pressure using setting screw (B) (clockwise higher and counter-clockwise lower).
37. After measuring and setting, replace the cover cap A and close the measuring nipple (C) again.
38. Remount the front cover of the appliance.

**Caution:** Check the measuring nipples used for gas tightness.

### 7.10 Carbon monoxide : carbon dioxide ratio

Atmos recommends that a carbon dioxide : carbon monoxide ratio test is carried out when the boiler is commissioned. This is best done when the CO<sub>2</sub> content of the flue gasses is measured. See the procedure described in § 7.9.

39. Set the boiler to the lowest output by simultaneously pressing the "Service" and "-" buttons on the operating panel until an  appears on the service display.
40. Measure the CO/CO<sub>2</sub> ratio.
41. Set the boiler to the high output by simultaneously pressing the "Service" and "+" buttons (twice) on the operating panel until an  appears on the service display.
42. Measure the CO/CO<sub>2</sub> ratio

The CO/CO<sub>2</sub> ratio at low or high output should be no higher than 0.004.

A CO/CO<sub>2</sub> ratio between 0.004 and 0.008 means that the appliance is '**At Risk**' (AR).

A CO/CO<sub>2</sub> ratio above 0.008 means that the appliance is '**Immediately Dangerous**' (ID)

Where an 'at risk' or 'immediately dangerous' situation is encountered, measures **must** be undertaken to rectify the situation. Particular attention should be given to the gas/air ratio, the integrity of the flue, or blockage in the heat exchanger. **Contact the manufacturer for assistance.**

## 8. FAULTS

When the controller detects a fault, the red fault LED flashes (above the *Reset* button) and a fault code is shown on the *Temperature* display.

After the fault has been remedied, the controller can be restarted by pressing the *Reset* button for 5 secs.

The following faults are detected and displayed:-

Temperature display	Description	Possible cause/remedy
10, 11, 12, 13, 14	Sensor fault S1	<ul style="list-style-type: none"> <li>• Check the wires for breaks</li> <li>• Replace S1</li> </ul>
20, 21, 22, 23, 24	Sensor fault S2	<ul style="list-style-type: none"> <li>• Check the wires for breaks</li> <li>• Replace S2</li> </ul>
0	Sensor fault after self-check	<ul style="list-style-type: none"> <li>• Replace boiler sensor S1 and/or S2</li> </ul>
1	Temperature too high	<ul style="list-style-type: none"> <li>• Air in system</li> <li>• Pump does not run</li> <li>• Too little circulation in system, radiators closed, pump setting too low</li> </ul>
2	Exchange S1 and S2	<ul style="list-style-type: none"> <li>• Check the cable loom</li> <li>• Replace S1 or S2</li> </ul>
4	No flame signal	<ul style="list-style-type: none"> <li>• Gas tap closed</li> <li>• Incorrect ignition distance</li> <li>• Gas inlet pressure too low or disappears</li> <li>• Gas valve or ignition unit does not receive voltage</li> </ul>
5	No flame signal	<ul style="list-style-type: none"> <li>• Condensate discharge blocked</li> <li>• Check setting of gas valve</li> </ul>
6	Flame detection fault	<ul style="list-style-type: none"> <li>• Replace ignition cable + spark probe</li> <li>• Replace ignition unit</li> <li>• Replace controller</li> </ul>
8	Fan speed incorrect	<ul style="list-style-type: none"> <li>• Fan rubs against casing</li> <li>• Wiring between fan and casing</li> <li>• Check the wires for poor contact (tacho signal)</li> <li>• Replace fan</li> </ul>
29, 30	Gas valve relay fault	<ul style="list-style-type: none"> <li>• Replace controller</li> </ul>

## 8.1 Burner does not ignite

Possible causes		Remedies
Gas tap is closed	⇒ Yes	1. Open the gas tap.
↓ No		
Air in the gas pipe.	⇒ Yes	1. De-aerate the gas pipe.
↓ No		
Inlet pressure too low.	⇒ Yes	1. Contact the gas company.
↓ No		
No ignition	⇒ Yes	1. Replace the ignition probe.
↓ No		
No spark. Ignition unit on gas unit faulty	⇒ Yes	1. Check the cabling. 2. Check the spark probe 3. Replace the ignition unit.
↓ No		
Gas-air control not adjusted properly.	⇒ Yes	1. Check the adjustment, see Gas-air control.
↓ No		
Fan faulty	⇒ Yes	1. Check the wiring. 2. Check the fuse. 3. Replace the fan if necessary.
↓ No		
Fan blockage	⇒ Yes	1. Clean the fan.
↓ No		
Gas valve faulty	⇒ Yes	1. Replace the gas valve. 2. Re-adjust the gas valve, see Gas-air control.

## 8.2 Burner ignites with much noise

Possible causes		Remedies
Inlet pressure too high.	⇒ Yes	1. The house gas meter may be faulty. Contact the gas company.
↓ No		
Incorrect ignition distance.	⇒ Yes	1. Replace the ignition probe. 2. Check the ignition probe distance.
↓ No		
Gas-air mixture not adjusted properly.	⇒ Yes	1. Check the adjustment. See Gas-air control.
↓ No		
Weak spark.	⇒ Yes	1. Replace the ignition probe. 2. Replace the ignition unit on the gas valve. 3. Check the ignition spark gap.

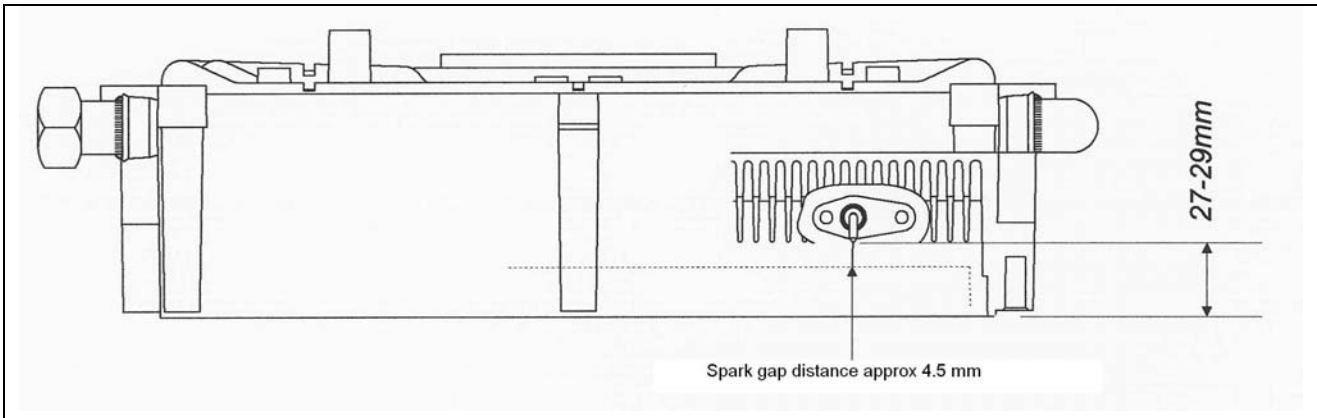

### 8.3 Burner resonates

Possible causes		Remedies
Inlet pressure too low.	⇒ Yes	1. The house gas meter may be faulty. Contact the gas company.
↓ No		
Re-circulation of the flue gases.	⇒ Yes	1. Check the flue gases and air supply.
↓ No		
Gas-air mixture not adjusted properly.	⇒ Yes	1. Check the adjustment, see Gas-air control.

### 8.4 No heating (CH)

Possible causes		Remedies
Room thermostat/weather-dependent control not closed or faulty.	⇒ Yes	1. Check the wiring. 2. Replace the thermostat. 3. Replace the weather-dependent control.
↓ No		
No voltage (24 V).	⇒ Yes	1. Check the wiring according to the diagram. 2. Check the connector x4. 3. Replace defective controller
↓ No		
Pump does not run.	⇒ Yes	1. Check the voltage. 2. Check the connector x4. 3. Replace defective pump. 4. Replace defective controller.
↓ No		
Burner does not operate on CH: - Sensor S1 or S2 faulty.	⇒ Yes	1. Replace sensor S1 or S2. See Fault code display: 1 or 2.
↓ No		
Burner does not ignite.	⇒ Yes	1. See Burner does not ignite.

## 8.5 Reduced output

Possible causes		Remedies
At high speed, the power has decreased by not more than 5%.	⇒ Yes	<ol style="list-style-type: none"> <li>1. Check appliance and flue system for pollution.</li> <li>2. Clean appliance and flue system.</li> </ol>

## 8.6 CH does not reach the correct temperature

Possible causes		Remedies
Room thermostat settings not correct.	⇒ Yes	<ol style="list-style-type: none"> <li>1. Check the setting and adjust if necessary: set to 0.1 A.</li> </ol>
↓ No		
Temperature set too low.	⇒ Yes	<ol style="list-style-type: none"> <li>1. Raise the CH temperature, see CH operation.</li> <li>2. Check the outside sensor for short circuit: remedy this..</li> </ol>
↓ No		
Pump does not run well. Pump setting too low.	⇒ Yes	<ol style="list-style-type: none"> <li>1. Raise the pump setting or replace the pump.</li> </ol>
↓ No		
No circulation in the system.	⇒ Yes	<ol style="list-style-type: none"> <li>1. Check for circulation: at least 2 or 3 radiators must be open.</li> </ol>
↓ No		
The boiler power is not set well for the system.	⇒ Yes	<ol style="list-style-type: none"> <li>1. Adjust the power, see Setting maximum CH power.</li> </ol>
↓ No		
No heat transfer due to scaling or pollution in the heat exchanger.	⇒ Yes	<ol style="list-style-type: none"> <li>1. Descale or flush the heat exchanger on the CH side.</li> </ol>

Table 6. NTC resistances

NTC 12 kOhm					
T [°C]	R[ohm]	T [°C]	R[ohm]	T [°C]	R[ohm]
-15	76020	25	12000	65	2752
-10	58880	30	9805	70	2337
-5	45950	35	8055	75	1994
0	36130	40	6653	80	1707
5	28600	45	5522	85	1467
10	22800	50	4609	90	1266
15	18300	55	3863	95	1096
20	14770	60	3253	100	952

## 9. SERVICING THE BOILER AND COMPONENT REPLACEMENT

### 9.1 SERVICING THE BOILER

The appliance and the system should be serviced annually by a qualified service engineer.

For appliances connected to propane gas, a six monthly service for the first two years to simply clean the condensate trap and pipe may be necessary. Due to the nature of propane gas, a jelly like substance can build up in the trap, causing it to become blocked.

#### 9.1.1 Preparation

Switch off the appliance using the *On/Off* button on the operating panel. Switch off the electrical supply to the appliance.

Close the gas tap.

Unscrew the two recessed screws left and right at the front underneath the appliance and lift/remove the front panel. See photo in § 4.4.3.

Wait until the appliance and the burner have cooled down. Swing out the expansion vessel by undoing the clip to raise the vessel slightly.

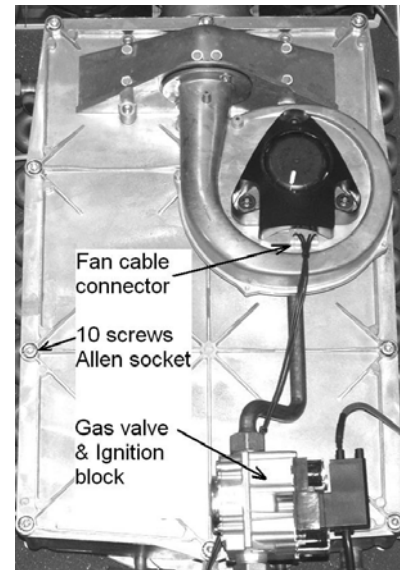

#### 9.1.2 Checking the heat exchanger and spark ignition probe

Remove the connector from the fan and the ignition block from the gas valve.

Disconnect the lower gas valve union.

Unscrew the 10 socket screws (Allen socket M8x40) from the front cover and remove this forwards complete with gas valve and fan.

While removing the front cover do not hold this at the gas valve or the fan. **Be careful not to damage the burner and the fan while removing the front plate.**

*The burner does not need any maintenance.*

**Never clean the burner with a brush or compressed air. This causes damage to the metal fibre.**

Check the spark ignition probe and gently clean any deposits. As the spark gap cannot be checked directly, use a flat surface across the corner of the heat exchanger to measure the distance to the probe. See the diagram in § 8.2. The distance should be in the range 27 to 29mm.

Replace the probe if necessary.

Remove the baffles that have been placed crosswise in the fins of the heat exchanger.

If necessary, clean the baffles and the fins of the heat exchanger from top to bottom with a brush or with compressed air.

If necessary, clean the bottom side of the heat exchanger and the condensate discharge at the bottom of the flue discharge behind the heat exchanger.

Reassemble the baffles in the heat exchanger.

Check the silicone gasket of the front cover for damage (hair cracks and/or discolouring) and replace if necessary.

Mount the front cover to the heat exchanger and attach this with the socket screws with spring washers. Crosswise tighten the socket screws evenly by hand. Using an Allen key, tighten the screws so that the front cover is closed onto the heat exchanger all round the edge, and then tighten up (approx 1/8<sup>th</sup> turn).

*Make sure that the silicon gasket is well placed around the front cover.*

Reconnect the gas union below the gas valve.

Check the sealing ring for damage and replace if necessary.

Fit the connector on the fan and the ignition block on the gas valve.

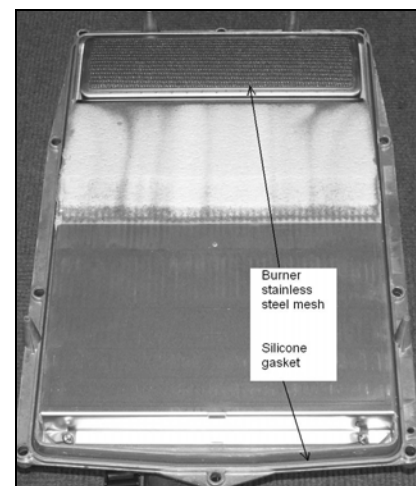
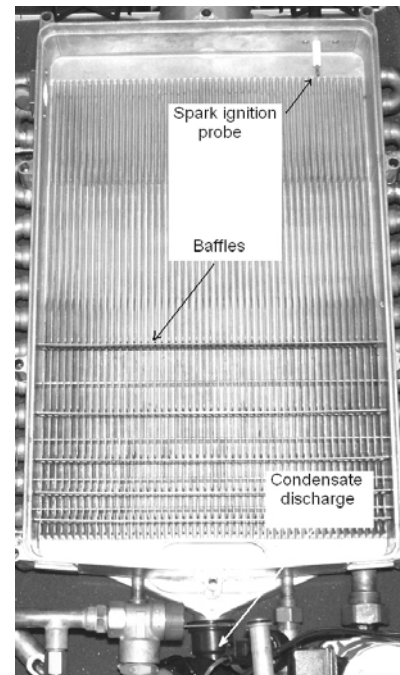

Open the gas tap and check the gas couplings below the gas valve and on the mounting bracket for leaks.

Switch on the electrical supply to the appliance

Switch on the appliance, using the *On/Off* button on the operating panel.

Check the front cover and the connection of the fan to the front cover for leaks.

### 9.1.3 Note for CFS systems with Non Return Valve (flue gas)

When refitting the fan, the NRV MUST be refitted (see diagram). Fold the silicon valve (1) of the NRV carefully into a U-form.

Place the valve + holder (1+2) into the hole of the front plate, making sure the valve is placed in the correct position (direction toward the front plate as shown). Replace the fan + seal back on the front plate, and screw both nuts (4) tight, making sure the valve stays in the right position.

### 9.1.4 Checking the condensate discharge

See the diagram in § 4.6.

Clean the condensate trap and the condensate discharge pipe.

After cleaning, fill the trap with water.

### 9.1.5 Inspect air supply/flue gas discharge system

Inspect the air supply/flue discharge system throughout its entirety, ensuring that it is in sound condition with no damage to the pipes or joints. Inspect the terminals ensuring that they are clear and unobstructed.

### 9.1.6 Checking the gas-air control

Check the gas-air control as given in § 7.9, and adjust as necessary.

### 9.1.7 Check the CO/CO<sub>2</sub> ratio

The CO/CO<sub>2</sub> ratio should be checked on each service. See section 7.10

### 9.1.8 Completion of inspection and service

Fit the front panel and replace the screws at the bottom of the appliance.

Check the CH system water pressure shown on the display, which should be minimum 1 bar and maximum 2 bar for a cold system.

Check the pressure of the expansion vessel is 1 bar, using a pump into the Schroeder valve if necessary.

Check the heating system for leaks and check the boiler, controls and system for correct operation.

Check the corrosion inhibitor concentration level within the CH system, topping up when necessary.

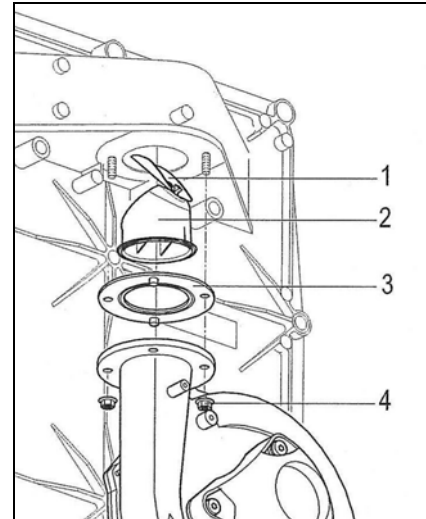

#### Note

After servicing, the Benchmark Checklist and Service Record (located at the back of this manual) should be completed and signed and the manual left with the customer.



## 9.2 COMPONENT REPLACEMENT

### 9.2.1 Preparation

Switch off the appliance using the *On/Off* button on the operating panel.  
Switch off the electrical supply to the appliance.

Close the gas tap.

Unscrew the two recessed screws left and right at the front underneath the appliance and lift/remove the front panel. See photo in § 4.4.3.

Wait until the appliance and the burner have cooled down.

Note – When removing cables/wires to the controller, the cable clamp must be released first by unscrewing 2 posidrive screws and the controller hinged down by unscrewing 2 posidrive screws as shown in diagram §5.3.

### 9.2.2 Gas valve/ ignition block

**Note: The gas valve is factory-preset and therefore only Atmos or their agents can supply these.**

Remove the spark ignition block by pulling apart horizontally. Undo the upper and lower unions, making sure that the 'O' rings and gas setting ring are not lost or damaged (see diagram in § 7.7). Replace the gas valve, and refit the unions and the ignition block.

Note: After replacing the gas valve, carry out the gas analysis adjustments as given in § 7.9.

If replacing the ignition block, then pull apart as above. Remove the push-fit cable to the probe and undo the X1 connections at the controller and earth. Replace the ignition block and make the connections.

### 9.2.3 Fan

Remove the electrical connector. Undo the upper union from the gas valve. Undo the two 8mm nuts as shown in the photo. Remove the assembly including the sealing ring. Undo the three Allen screws (M4x10) to remove the gas inlet sub assembly. Fit the replacement fan in reverse order. Check the sealing ring is not damaged and replace if necessary; check that it seals correctly.

See also § 9.1.3 for appliances fitted with Non Return Valve (flue gas).

### 9.2.4 Controller

If possible, record the parameters as described in § 7. Remove the display cover and undo the two posidrive screws to drop down the controller panel as shown in the diagram in § 5.3.

Pull apart the connectors and undo the 8mm nut to allow the controller assembly to be removed and replaced. After replacement, set the parameters, as described in § 7, to the previously recorded values, if available, or as described in § 6 and § 7.

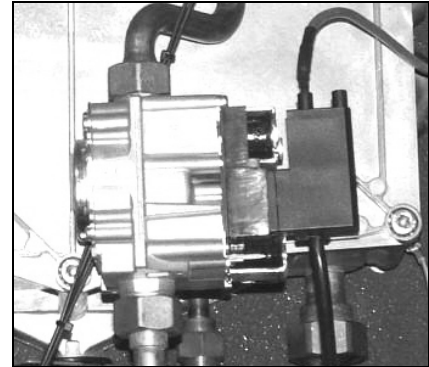

#### Note

Appliances manufactured after 1<sup>st</sup> January 2009 have a Torx T10 screw holding the ignition block on the gas valve. Remove this screw prior to pulling the ignition unit off.

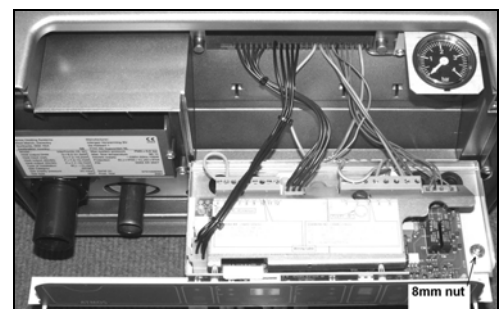
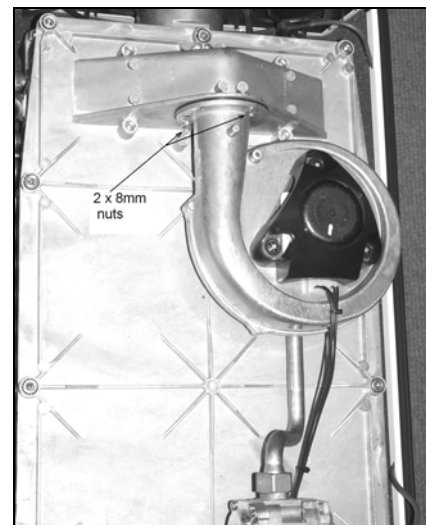



### 9.2.5 Burner/ spark ignition probe

Remove the front cover of the heat exchanger as described in § 9.1.2. Unscrew the 4 screws shown on the photo to allow the stainless steel burner mesh to be removed. These screws are Torx 20 (RVS A2 4,2x25") or Allen bolt M4x20 (units before 2006). The burner gasket should be checked and replaced if damaged. Replace the burner mesh assembly and refit the screws.

The spark ignition probe is shown in the photo in § 9.1.2 and also the diagram in § 8.2. To replace the probe, pull off the ignition cable and unscrew the 2 screws (Allen bolt M4x8). The seal should be checked and replaced if damaged. Replace the probe and refit the seal and the screws. Check the spark gap and replace the front cover, as described in § 9.1.2.

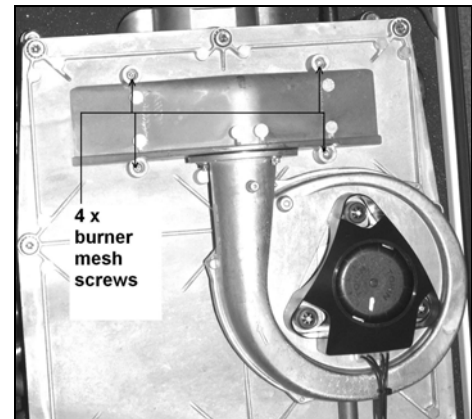

### 9.2.6 Flow/ return temperature sensors

The supply temp. sensor is located above the return temp. sensor. The latter is shown in the photo. Disconnect the two pin connector and release the spring clip. Pull out the sensor and replace.

**Note: The replacement of the components below this box requires the appliance to be drained:-**  
 CH side – Drain the appliance using the drain tap and drain the system at the lowest point.  
 After replacement, refill the appliance as given in § 6.1.

### 9.2.7 Pressure relief valve

Remove the plastic pipe from the safety discharge. Undo the pressure sensor capillary and undo the union at the connection with the CH flow pipe. Remove the pressure relief valve and inlet pipe. Remove the plastic fitting from the discharge and undo the pipe connection to allow removal of the valve. Fit replacement valve in reverse order using a sealant suitable for potable water.

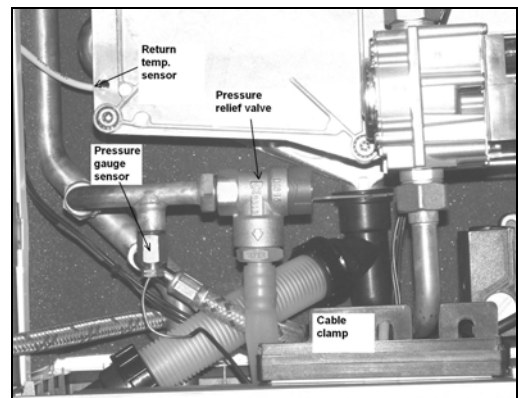

### 9.2.8 Pressure gauge sensor

Undo the pressure sensor capillary and unscrew the two posidrive screws to release the cable clamp. Remove the gauge and capillary, and replace.

### 9.2.9 Pump head

Disconnect the pump wires from the controller (see note in § 9.2.1). Undo two Allen bolts on the Wilo pump head (alternative pump Grundfos has 4 Allen bolts) to remove the pump head from the body. Fit replacement pump head in reverse order. The pump must be vented via its vent plug after refilling the appliance.

### 9.2.10 Expansion vessel

Unscrew the flexible hose connection, making sure that the sealing ring is not damaged. Unclip the bracket holding the vessel and fit replacement including the sealing ring. Using the Schroeder valve on the expansion vessel, and pump if required, check the pressure is 1 bar.

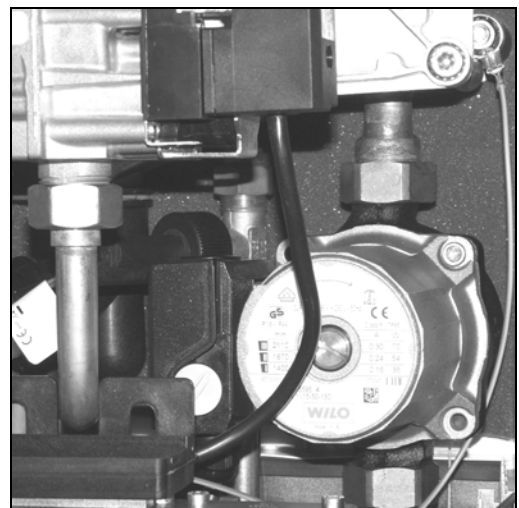

## 10. TECHNICAL SPECIFICATIONS

Appliance category	B13; B33; C13; C 33; C 43; C53; C63; C83
Gas inlet pressure	20 mbar
Suitable for gas	II <sub>2</sub> H <sub>3</sub> P

Technical data			
	InterSystem HE 26		

CH			
Heat power input (gross)*	kW	8.0 – 30.3	
Heat power input (net)*	kW	7.2 – 27.3	
Heat output at 80/60°C*	kW	7.0 – 26.2	
Heat output at 50/30°C*	kW	7.7 – 26.8	
Max. CH water pressure	bar	2.5 (see note 1)	
CH operating pressure	bar	1 – 2 (see note 2)	
Max. CH water temperature	°C	90	

Other data			
Gas consumption	m <sup>3</sup> /h	0.85 - 3.25	

Electrical data			
Mains voltage	V	230	
Protection class		IP44 (B(.)=IP20)	
Consumed power: full load	W	105	
Consumed power: partial load	W	40	
Consumed power: standby	W	2.4	

Overall dimensions and weight			
Height	mm	810	
Width	mm	450	
Depth	mm	270	
Weight	kg	39	

\*The maximum CH power is set to 50% of the highest value at the factory (see Setting CH power).

Notes 1 - Safety discharge valve is 3 bar.

2 – Min pressure 1 bar ( expansion vessel pre-charge is 1 bar).

## 10.1 Electrical diagram

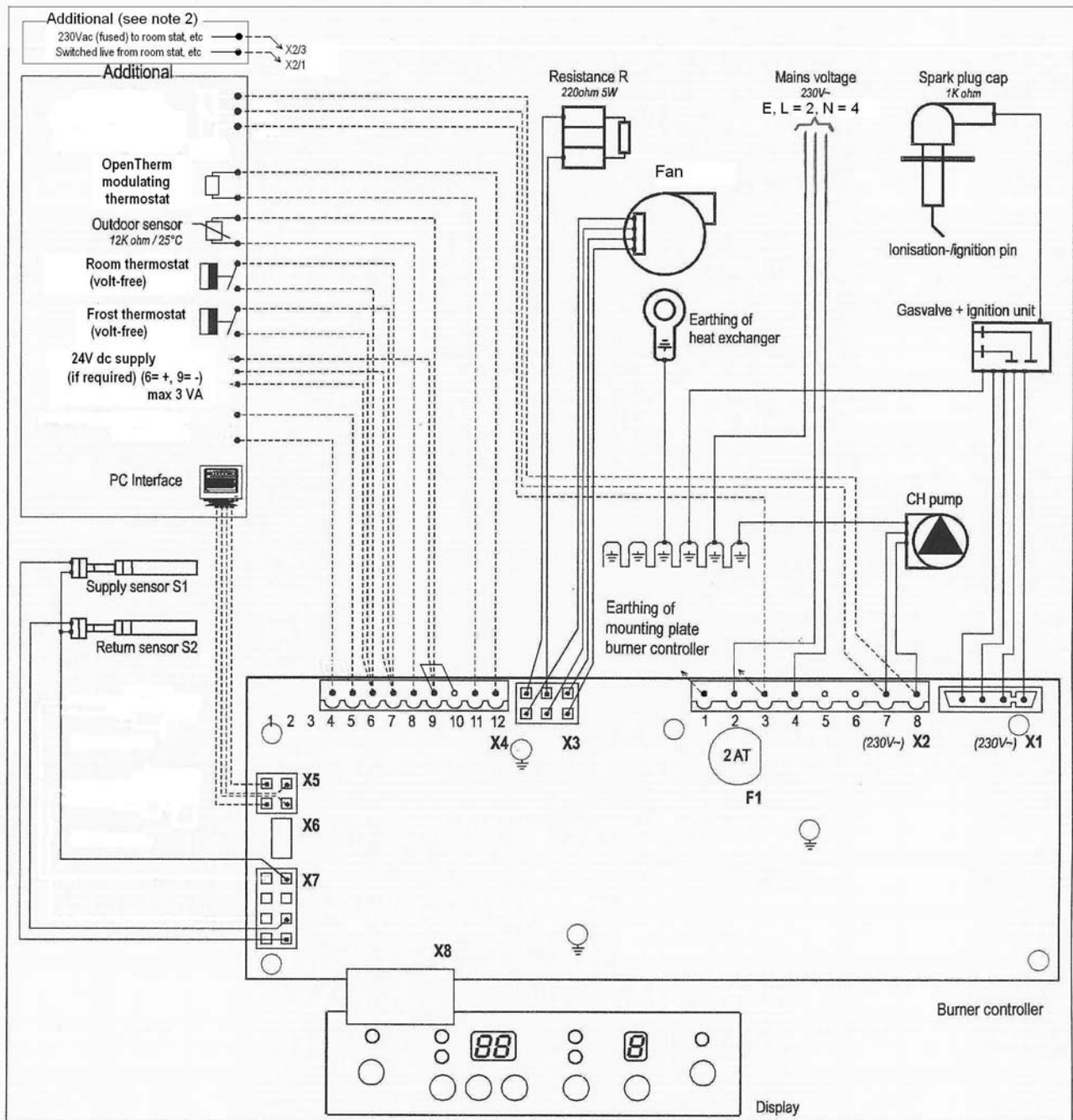

### Notes

1. F1: 5x20mm anti-surge fuse, 2A.
2. **230Vac stat circuit:** Available for room stat, etc. The switched live can also be used for S plan or Y plan circuits (note that the 230Vac live to the Wiring Centre must come from the same fused spur as the 230Vac supply to the boiler).
3. **OpenTherm:** When using an OpenTherm thermostat, 6-7 must not be used.

## 11. CE DECLARATION

Declaration of conformity according to ISO IEC GUIDE 22.

Manufacturer: Atmos Heating Systems  
Address: West March, DAVENTRY, Northants, NN11 4SA

Hereby declares that the application:

Atmos, Type InterSystem HE26

Meets the stipulations of the following directives:

- Machine directive (89/392/EC) as amended in directive (93/68/EC)
- Low voltage directive (73/23/EC) as amended in directive (93/68/EC)
- Directive concerning gas appliances (90/396/EEG)
- Boilers Efficiency Directive for new oil and gas fired central heating boilers (92/42/EC)
- EMC Directive (89/336/EC) as most recently amended in directive (93/68/EC).

Daventry, 5 January 2010



J.A. Thomason BSc (Eng)  
Director







# SERVICE RECORD

It is recommended that your heating system is serviced regularly and that the appropriate Service Record is completed.

## Service Provider

Before completing the appropriate Service Record below, please ensure you have carried out the service as described in the manufacturer's instructions.

Always use the manufacturer's specified spare part when replacing controls.

### SERVICE 1          Date

Energy Efficiency Checklist completed? Yes  No

Engineer Name

Company Name

Telephone Number

Gas Safe Register Number

Comments

Signature

### SERVICE 2          Date

Energy Efficiency Checklist completed? Yes  No

Engineer Name

Company Name

Telephone Number

Gas Safe Register Number

Comments

Signature

### SERVICE 3          Date

Energy Efficiency Checklist completed? Yes  No

Engineer Name

Company Name

Telephone Number

Gas Safe Register Number

Comments

Signature

### SERVICE 4          Date

Energy Efficiency Checklist completed? Yes  No

Engineer Name

Company Name

Telephone Number

Gas Safe Register Number

Comments

Signature

### SERVICE 5          Date

Energy Efficiency Checklist completed? Yes  No

Engineer Name

Company Name

Telephone Number

Gas Safe Register Number

Comments

Signature

### SERVICE 6          Date

Energy Efficiency Checklist completed? Yes  No

Engineer Name

Company Name

Telephone Number

Gas Safe Register Number

Comments

Signature

### SERVICE 7          Date

Energy Efficiency Checklist completed? Yes  No

Engineer Name

Company Name

Telephone Number

Gas Safe Register Number

Comments

Signature

### SERVICE 8          Date

Energy Efficiency Checklist completed? Yes  No

Engineer Name

Company Name

Telephone Number

Gas Safe Register Number

Comments

Signature

### SERVICE 9          Date

Energy Efficiency Checklist completed? Yes  No

Engineer Name

Company Name

Telephone Number

Gas Safe Register Number

Comments

Signature

### SERVICE 10          Date

Energy Efficiency Checklist completed? Yes  No

Engineer Name

Company Name

Telephone Number

Gas Safe Register Number

Comments

Signature

